



FLORIDA GATEWAY COLLEGE

INVITATION TO BID

ITB #
RP-24-01-04

PROJECT NAME
Repaving of Parking Lot #11

BID DUE
February 12, 2024
by no later than 2:00 p.m. (EST)

Florida Gateway College
149 SE College Place
Lake City, FL 32025
(386) 754-4381

**FLORIDA GATEWAY COLLEGE
INVITATION TO BID**

ITB #RP-24-01-04

Repaving of Parking Lot #11

CONTENTS

1. Legal Advertisement / Invitation to Bid
2. Bid Schedule
3. Instructions to Bidders
4. Specifications
5. Attachment No. 1 – Supplementary Conditions
6. Attachment No. 2 – Agreement Between Owner and Contractor
7. Attachment No. 3 – Bid Proposal Form
8. Attachment No. 4 – List of Subcontractors
9. Attachment No. 5 – Identical Tie Bids Statement
10. Attachment No. 6 – Public Entity Crimes Sworn Statement
11. Attachment No. 7 – Application and Certificate for Payment
12. Attachment No. 8 – Performance Bond
13. Attachment No. 9 – FGC Dropbox Submittal Instructions
14. Attachment No. 10 – Bidders Checklist
15. Attachment No. 11 – Federal Contracting Requirements
16. Attachment No. 12- Davis Bacon Wages
17. Attachment No. 13- Design Plans
18. Attachment No. 14- Pavement Evaluation Report

LEGAL ADVERTISEMENT / INVITATION TO BID

THE DISTRICT BOARD OF TRUSTEES
OF FLORIDA GATEWAY COLLEGE
WILL RECEIVE BIDS FOR THE FOLLOWING:

REPAVING OF PARKING LOT #11
FLORIDA GATEWAY COLLEGE
LAKE CITY, FLORIDA
FGC ITB NUMBER: RP-24-01-04

I. ORGANIZATION

Florida Gateway College

II. PURPOSE

Florida Gateway College (COLLEGE) is seeking Invitations to Bid (ITB) from experienced contractors to repave Parking Lot #11 located on campus.

III. PROJECT DESCRIPTION

Services are expected to include the repaving of Parking Lot # 11 on Florida Gateway College campus. Construction tasks for this project consist of, but are not limited to, regrading, parking lot paving and drainage improvements of existing parking lot.

IV. CONTRACTOR PRE-QUALIFICATION

There will be no Contractor Pre-Qualification needed for this project.

V. INQUIRIES

Inquiries concerning this ITB should be directed to Kathrine Harris, Director of Procurement and Contracts, by email at kathrine.harris@fgc.edu.

VI. PRE-BID CONFERENCE

All interested bidders are required to attend the Mandatory Pre-Bid Conference to be held at Parking Lot #11 on campus.

A. Pre-Bid Conference

Date & Time	Monday, January 29, 2024 @ 10:00 a.m. (EST)
Address	149 SE College Place, Lake City, FL 32025

VII. SUBMISSION OF BIDS

Bids must be electronically submitted to the FGC Dropbox prior to the deadline. FGC Dropbox submittal instructions are located hereunder in Attachment No. 9. It is the Respondents' responsibility to ensure their bid is timely submitted and received by COLLEGE. COLLEGE will not be responsible for delays that cause a bid to arrive after the designated submission deadline. A bid received by COLLEGE after the deadline will not be considered. Once opened, a bid becomes the property of COLLEGE and will not be returned.

A. OPENING DATE

The bid window will open no earlier than **12:00 p.m. (EST) on Monday, January 29, 2024.**

B. CLOSING DATE

Bid’s must be received no later than **2:00 p.m. (EST) on Monday, February 12, 2024.**

Bids will be opened via Zoom in an open public bid meeting, in electronic format, and can be viewed by Bidders.

Date & Time	Monday, February 12, 2024 @ 2:00 p.m. (EST)
Meeting ID	856 8407 7862
Passcode	NuSQb5
Topic	ITB# RP-24-01-04 Repaving of Parking Lot #11
Join the meeting at https://us05web.zoom.us/j/85684077862?pwd=fuZlUCDbGXXPo38bHkm7kBbR7EylkA.1	

VIII. BID DOCUMENTS

All available forms pertaining to this ITB are available from the Procurement and Contracts Department at:

Florida Gateway College
 149 SE College Place
 Lake City, FL 32025
 (386) 754-4364
Kathrine.harris@fgc.edu

IX. RIGHT TO WAIVE IRREGULARITIES & TECHNICALITIES

COLLEGE reserves the right to waive minor irregularities and/or technicalities associated with this solicitation. The Procurement and Contracts Department of COLLEGE shall be the final authority regarding waivers of irregularities and technicalities.

FOR THE DISTRICT BOARD OF TRUSTEES
 OF FLORIDA GATEWAY COLLEGE
 Lawrence Barrett, President

END OF SECTION

BID SCHEDULE

Action	Date & Time
Legal Advertisement Published https://www.fgc.edu/community/procurement-and-contracts/solicitations-goods-services/	January 18, 2024 No later than 5:00 p.m. (EST)
Mandatory Pre-Bid Conference Parking Lot #11 149 SE College Place, Lake City, FL 32025	January 29, 2024 From: 10:00 a.m. (EST) To: 11:00 a.m. (EST)
Last Day for Bidder Questions	February 5, 2024 No later than 5:00 p.m. (EST)
Written Response to Bidder Questions via Addendum	February 7, 2024 No later than 5:00 p.m. (EST)
Bid Proposal Due Monday, February 12, 2024 @ 2:00 p.m. https://us05web.zoom.us/j/85684077862?pwd=fuZlUCDbGXXPo38bHkm7kBbR7EylkA.1	February 12, 2024 Must be received no later than 2:00 p.m. (EST)
Posting of Notice of Intent to Award https://www.fgc.edu/florida-gateway-college/procurement-contracts/solicitations-goods-services/	February 15, 2024
Contract Signed / Notice to Proceed	February 15, 2024

The Bid Schedule is a tentative schedule the COLLEGE will follow throughout the bid process. This schedule is subject to change at the discretion of the COLLEGE.

END OF SECTION

INSTRUCTIONS TO BIDDERS
ITB # RP 24-01-04

1. DEFINITIONS

Addenda – Written and/or graphic revisions issued prior to the award and execution of the Contract which, modify and/or interpret the Contract Documents by additions, deletions, clarifications, or corrections. Addenda will become part of the Contract Documents when the Contract is awarded and executed.

Application for Payment – Statement of amounts claimed by Contractor as payments due on account of work performed or materials suitably stored.

Bidder – An individual, firm, association, joint venture, partnership, syndicate, corporation, or group that submits a bid proposal in response to an ITB.

Bid Proposal – The forms, including all items related thereto, envelopes, and all other information pertaining to the entire bid, complete and properly executed, which the Bidder has submitted as his Bid Proposal for the work completed.

Change Order – A work order, issued after the award and execution of the Contract, signed by the Owner, authorizing a change in the scope of the work during construction.

Contract – The Agreement between Owner and Contractor consisting of: The agreement text preceding the signature of the parties, the Bonds as required, the Certificates of Insurance, and any other documents as may be required by the Contract Documents.

Contract Documents – Consist of the Agreement between Owner and Contractor, Instructions to Bidders (Bid Package ITB# RR-24-1-02) and attachments thereto, Plans, Performance Bond, Addenda issued prior to execution of the Contract, Modifications issued after execution of the Contract, the proposal submitted by the Contractor, and such other documents as are made a part of same by reference in any of the Contract Documents.

Contractor – An individual or a business entity that, as a result of having been awarded this ITB, has entered into a Contract with the Owner.

Invitation to Bid (ITB) – A formal request to prospective vendors soliciting bids, which contains the specifications or scope of services, and all contractual terms and conditions.

Lowest Responsible Bidder – The Bidder who has submitted a responsive Bid Proposal at the lowest price of all the responsive Bid Proposals submitted and who's past performance and financial capability is deemed acceptable.

Owner – Owner is the District Board of Trustees of Florida Gateway College, a Body Politic, identified as such in the Agreement and is referred to throughout the Contract Documents as if singular in number and masculine in gender. The term Owner shall mean Owner, Florida Gateway College, and College. The terms Owner, Florida Gateway College, and College are used interchangeably throughout this document.

Plans – The official plans and drawings or reproductions thereof, pertaining to the work to be performed.

Project – All work specified and described in the Contract documents.

Responsible Bidder – A Bidder who has the capability in all respects to perform fully the Contract requirements, and the experience, integrity, reliability, capacity, facilities, equipment, and credit that will assure good faith performance.

Responsive Bidder – A Bidder who has submitted a Bid Proposal that conforms in all material respects to the requirements stated in the ITB.

Subcontractor – Any individual, firm, partnership, or corporation entering into an agreement to furnish materials and labor for the work specified and described in the Contract documents.

Time of Completion – The number of calendar days, or the actual date, by which the work is required to be completed.

2. EXAMINATION

Bidders are required to carefully examine all Instructions to Bidders, Specifications, Supplementary Conditions, Plans, and any Addenda to become thoroughly familiar with all work to be performed under the Contract.

3. PROJECT SITE

Bidders are encouraged to visit the project site to become familiar with the local conditions that may, in any manner, affect the work to be performed and the equipment, materials, and labor required. Site visits are by appointment only.

4. PRE-BID CONFERENCE

As indicated in the Advertisement for Bids, Bidders are REQUIRED to attend the Mandatory Pre-Bid Conference on the date, time, and place outlined in the Advertisement for Bids. This Pre-Bid Conference will be held in order to more fully explain the scope of work covered by the Contract Documents and to allow questions to be asked by the Bidders. If deemed necessary, an Addendum will be issued to Specifications and/or plans as necessary to change, modify or explain any decisions or other information that comes out at this Pre-Bid Conference.

5. POINT OF CONTACT

The sole point of contact for all matters relating to this ITB is:

Kathrine Harris
Director, Procurement and Contracts
Florida Gateway College
149 SE College Place
Lake City, Florida 32025
(386) 754-4381
kathrine.harris@fgc.edu

6. CLARIFICATION

No oral clarification will be given in regard to the meaning of Instructions to Bidders, Specifications, or Plans, and no oral instructions will be given before the award and execution of the Contract. Discrepancies, omissions, or doubts as to the meaning of Contract Documents shall be given in writing to the College for interpretation not later than the date and time specified in the Bid Schedule provided herein. A written response to Bidder questions will be provided by the date and time specified in the Bid Schedule provided herein.

7. ADDENDA

Any addenda issued prior to the opening of bid proposals for the purpose of changing the intent of the Instructions to Bidders, Specifications, Supplementary Conditions, and Plans, or clarifying the meaning of the same, shall be binding in the same way as if written in the Instructions to Bidders, Specifications, Supplementary Conditions, and Plans. It is the bidder’s responsibility to check with the Procurement and Contracts Department prior to submitting a bid to make sure they have not missed any addendums.

The College will also post all addenda and materials relative to this procurement on the Procurement a Contracts website:

<https://www.fgc.edu/florida-gateway-college/procurement-contracts/solicitations-goods-services/>

Interested parties are responsible for monitoring this site for new or changing information relative to this procurement.

8. QUALIFICATIONS OF BIDDER

This bid does not require pre-qualification

9. PREPARATION OF BIDS

- a. Each Bidder shall use the Bid Proposal Form included herein, indicating base bid amount in the proper space. Any erasures or other corrections in the Bid Proposal must be explained or noted over the signature of the Bidder. Bid Proposals containing any conditions, omissions, unexplained erasures, alterations, items not called for, or irregularities of any kind may be rejected by the Owner.
- b. All bid prices shall be stated in both words and numerals.
- c. Each Bid Proposal must give the full business address of the Bidder and state whether it is an individual, corporation, or partnership. Bid Proposals by a corporation must be signed with the legal name and seal of the corporation, followed by the name of the State of its incorporation, and by the manual signature and designation of an officer, agent, or other person authorized to bind the corporation, and if the person signing is not the President, be accompanied by a duly authenticated document evidencing the authority to the officer or agent. Bid Proposals by partnerships shall show the names of all partners and must be signed in the partnership name by one of the partners. The partnership signature shall be followed by the manual signature of the partner signing. In every case, the name of the person signing, and his designation shall be typed or printed below his signature. Bid Proposals by a person who affixes to his signature the word “President”, “Secretary”, “Agent”, or other designation without disclosing his principal may be held to the terms of the Bid Proposal by the individual so signing. Satisfactory evidence of the authority of an officer, agent, attorney, or other person signing for a corporation, and agent, attorney, etc. signing for a partnership or an individual shall be furnished.

10. ORGANIZATION OF THE BID PACKAGE

The Bid Proposal should be assembled in the following manner:

- a. Bid Proposal Form: Attachment No. 3
- b. List of Subcontractors: Attachment No. 4
- c. Identical Tie Bids Statement: Attachment No. 5
- d. Public Entity Crimes Sworn Statement: Attachment No. 6

11. SUBMISSION OF BIDS

Bid Proposals with all items related thereto, must be electronically submitted to the FGC Dropbox not later than the date and time specified in the Bid Schedule provided herein. Failure to comply with these requirements shall be cause for rejection of the Bid Proposal. Instructions on submitting Bid Proposals to the FGC Dropbox is listed on Attachment No. 9.

12. LIST OF SUBCONTRACTORS

In accordance with Section 255.0515, Florida Statutes, Bidder must submit a list of the subcontractor's bidder intends to use on this project.

13. LATE BIDS

Bid Proposals must be electronically submitted to the FGC Dropbox prior to the specified bid opening date/time. Bid Proposals received after that time will not be accepted. The College will not be responsible for delays that cause a Bid Proposal to arrive after the designated bid opening date/time. Bids are for "ITB #RP-24-01-04 Repaving of Parking Lot #11, BID OPENING in accordance with the date and time specified in the Bid Schedule provided herein".

14. WITHDRAWAL OF BID

A Bidder may withdraw his Bid without prejudice to himself, not later than the date and time set for opening of Bid Proposals, by communicating the Bidder's purpose in writing to the Owner. The Bid Response will be returned unopened.

15. DISQUALIFICATION

More than one Bid Proposal from an individual, firm, partnership, corporation, or association under the same or different names will not be considered. Reasonable grounds for believing that a Bidder is interested in more than one Bid Proposal for the same work will cause rejection of all Bid Proposals in which such Bidders are believed to be interested. Any or all Bid Proposals will be rejected if there is reason to believe that collusion exists among the Bidders. No participants in such collusion will be considered in future Bid Proposals for the same work. Bid Proposals in which the prices obviously are unbalanced may be rejected.

16. PUBLIC OPENING OF BIDS

Bid Proposals will be opened publicly at the time and place stated in the Advertisement for Bids.

17. REJECTION OF BIDS

The College reserves the right to reject any or all Bid Proposals received and to waive any informality or technicality in the Bid Proposals received whenever such rejection or waiver is in the best interest of the College.

18. AWARD OF CONTRACT

Award of the contract will be made to that responsible Bidder whose Bid Proposal, conforming to the Invitation to Bid, is most advantageous to the College, price and other factors considered.

19. CONTRACT AND BONDS

- a. Contractor shall execute the contract within seven calendar days from date of receipt and return to the Owner for his execution, along with all required bonds and insurance certificates. Contractor shall begin work upon receipt of a Notice to Proceed issued by Owner.
- b. All work shall be Finally Complete 30 days after Notice to Proceed has been issued.

- c. Contractor shall maintain sufficient labor and supervision on the project site until all items have been completed. A Final Review with the Owner's Representative and Contractor will be scheduled upon completion of all items.

20. PERFORMANCE BOND

A Performance Bond in the penal sum of not less than 100 percent of the Contract amount, with a Surety Company satisfactory to the Owner and licensed to conduct business in the State of Florida, will be required of the Contractor for any resulting contract in excess of \$100,000 guaranteeing that the Contract, including the various guarantee periods thereunder, will be faithfully performed. The bond shall be delivered to the Owner simultaneously with Contractor's execution of the Contract.

21. COMMENCEMENT

At the Preconstruction Conference, the Owner shall make arrangements with the Contractor for the assignment of staging area to be used at the site for storage of materials, parking, sheds, trailers, etc. During the construction, the Contractor shall maintain the areas in neat condition. The storage of materials for use in this project shall in no way interfere with, or make hazardous, existing walkways, driveways, etc. Existing trees and landscaping shall be protected from injury. Work shall begin upon receipt of a Notice to Proceed issued by Owner.

22. FAMILIARITY WITH LAWS

The Bidder is assumed to be familiar with all Federal, State, and local laws, ordinances, rules, and regulations that in any manner, affect the work. Ignorance on the part of the Bidder will in no way relieve him from responsibility.

23. EQUALITY AND SUBSTITUTIONS

If the bidder proposes to furnish a 'different' product from that specified, he shall submit in writing copies of detailed specifications and catalog cuts (with information copy to the) clearly identified, and clearly stating the differences from the product specified, the date and time specified in the Bid Schedule provided herein, to the department of Procurement and Contracts at Florida Gateway College for evaluation and approval to bid. The Florida Gateway College Director of Procurement and Contracts will issue an addendum adding acceptable equivalent items to the bid items involved. The Owner and the Owner's Representative shall not be responsible for locating or securing any information that is not identified properly on the information supplied for evaluation of the proposed equivalent product.

24. PROPRIETARY INFORMATION

Bid Proposals submitted shall not include any proprietary data or other proprietary information. All documents and other information included with the Bid Proposal becomes public information upon the opening of the Bid Proposal.

25. IDENTICAL OR TIE BIDS

In accordance with Section 287.087 Florida Statutes, preference shall be given to a business with drug-free workplace programs in the identical Tie Bids. To qualify, the Bidder must have implemented the program identified on the enclosed form and attach the executed form with his/her bid proposal.

26. DISCRIMINATORY VENDOR

An entity or affiliate who has been placed on the discriminatory vendor list may not submit a bid on a contract to provide goods or services to a public entity, may not submit a bid on a contract with a public entity for the construction or repair of a public building or public work, may not submit bids on leases of real property to a public entity, may not award or perform work as a contractor, supplier,

subcontractor, or consultant under contract with any public entity, and may not transact business with any public entity.

27. PUBLIC ENTITY CRIMES STATEMENT

A person or affiliate who has been placed on the convicted vendor list following a conviction for a public entity crime may not submit a bid to provide any goods or services to a public entity for a period of 36 months from the date of being placed on the convicted vendors list.

28. INDEMNIFICATION

To the fullest extent permitted by law, the Contractor shall indemnify and hold harmless the Owner and the Owner Representative and their agents and employees from and against all claims, damages, losses, and expenses, including but not limited to attorneys' fees, arising out of or resulting from the performance of the Work, provided that any such claim, damage, loss or expense (1) is attributable to bodily injury, sickness, disease or death, or to injury to or destruction of personal property including the loss of use resulting there from, and (2) is caused in whole or in part by any negligent act or omission of the Contractor, any Subcontractor, anyone directly or indirectly employed by any of them or anyone for whose acts any of them may be liable, regardless of whether or not it is caused in part by the negligence of a party indemnified hereunder. Such obligations shall not be construed to negate, abridge, or otherwise reduce any other right or obligation of indemnity which would otherwise exist as to any party or person. The parties agree that neither this provision nor any provision of the agreement shall waive the benefits or provisions of Chapter 768.28, Florida Statutes, or similar provision of law. Nothing herein shall be construed to create any third-party beneficiary rights in any person or entity not a party to this Contract.

29. PAYMENTS

Progress payments, final payment, and payment to subcontractors and material men shall be made in accordance with Article 5 of Attachment No. 2 Agreement between Owner and Contractor.

30. OWNERS RIGHT TO STOP WORK

If the Contractor fails to correct defective Work or persistently fails to supply materials or equipment in accordance with the Contract Documents, the Owner may order the Contractor to stop the Work, or any portion thereof, until the cause for such order has been eliminated. The Contractor will not be entitled to a time extension of the contract completion time in the event the Owner exercises his rights under this paragraph.

31. OWNER'S RIGHT TO CARRY OUT THE WORK

If the Contractor defaults or neglects to carry out the Work in accordance with the Contract Documents or fails to perform any provision of the Contract, the Owner may, after seven (7) days written notice to the Contractor and without prejudice to any other remedy he may have, make good such deficiencies. In such case an appropriate Change Order shall be issued deducting from the payments then or thereafter due the Contractor the cost of correcting such deficiencies, including the cost of the Owner Representative's additional services made necessary by such default, neglect, or failure. The Owner Representative must approve both such action and the amount charged to the Contractor. If the payments then or thereafter due the Contractor are not sufficient to cover such amount, the Contractor shall pay the difference to the Owner.

32. CHANGE ORDERS

A Change Order is a written order to the Contractor signed by the Owner, issued after the execution of the Contract, authorizing a Change in the Work or an adjustment in the Contract Sum or the

Contract Time. A Change Order will also be signed by the Contractor if he agrees to the adjustment on the Contract Sum or the Contract Time. The Contract Sum and the Contract Time may be changed only by Change Order.

The Owner, without invalidating the Contract and without notice to the sureties, may order changes in the Work within the general scope of the Contract consisting of additions, deletions, or other revisions, the Contract sum, and the Contract time being adjusted accordingly. All such Changes in the Work shall be authorized by Change Order and shall be executed under the applicable conditions of the Contract Documents.

The cost or credit to the Owner resulting from a Change in the Work shall be determined by mutual acceptance of a lump sum amount with the cost properly itemized. The Contractor may add an amount equal to 10% of the total cost for profit.

33. E-VERIFY

In order to meet all Federal, State, and Local employment laws, Florida Gateway College adheres to the E-Verify registration of Contractors that are to perform services as a result of this Invitation to Bid. The Contractor selected to provide services under this solicitation is required to utilize the U.S. Department of Homeland Security's E-Verify system, in accordance with the terms governing the use of the system, to confirm the employment eligibility of; 1. All persons employed by the Contractor during the term of the Contract to perform employment duties within Florida; and 2. All persons, including subcontractors, assigned by the Contractor to perform work pursuant to the Contract with Florida Gateway College.

34. NOTICE OF BID PROTEST, BONDING REQUIREMENT

A bidder who wishes to file a protest pertaining to an Invitation to Bid (ITB) must file such notice in accordance with procedures prescribed by Section 120.57(3) Florida Statutes (F.S.). All protests must be filed with the College's Director of Procurement & Contracts. A protest is officially filed when it is received in the Director's office.

Any person who is adversely affected by the district decision or intended decision shall file with the Director of Procurement and Contracts a notice of protest in writing within 72 hours after the posting of the intent to award or after receipt of the notice of the College's decision or intended decision and shall file a formal written protest within ten days after filing the notice of protest. With respect to a protest of the specifications contained in an invitation to bid, the notice of protest shall be filed in writing within 72 hours after the receipt of the notice of the project plans and specifications or intended project plans and specifications in an invitation to bid, and the formal written protest shall be filed within ten days after the date of the notice of protest is filed. Failure to file a protest within the time prescribed in Section 120.57(3), Florida Statutes, or failure to post the bond or other security required by law within the time allowed for filing a bond shall constitute a waiver of proceedings under Chapter 120, Florida Statutes. The formal written protest shall state with particularity the facts and law upon which the protest is based. Saturdays, Sundays, and state holidays shall be excluded in the computation of the 72-hour time periods provided by this paragraph.

As prescribed by F.S. 255.0516, any protester who files an action protesting a decision or intended decision pertaining to a bid pursuant to F.S. 120.57(3)(b) shall post at the time of filing the formal written protest, a bond payable to Florida Gateway College in an amount equal to twenty-five thousand dollars or two percent of the lowest accepted bid, whichever is greater, for projects valued over five hundred thousand dollars or five percent of the lowest accepted bid for all other projects.

The bond shall be conditioned upon payment of all costs and fees which may be adjudged against the protester in the administrative hearing in which the action is brought in any subsequent appellate court proceedings. In lieu of a bond, a cashier's check, certified bank check, bank certified company check, money order, or U.S. currency would be acceptable form of security. If, after completion of the administrative hearing process and any appellate court proceedings, the district prevails, it shall recover all costs and charges, which shall be included in the final order or judgment, including charges made by the Division of Administrative Hearings, but excluding attorney's fees. Upon payment of such costs and charges by the protester, the protest security shall be returned. If the protester prevails, he shall recover from the College all costs and charges which shall be included in the final order of judgment, excluding attorney's fees. **FAILURE TO FILE THE PROPER BOND AT THE TIME OF FILING THE FORMAL PROTEST WILL RESULT IN A DENIAL OF THE PROTEST.**

35. Disposition of the protest shall follow 120.57 F.S. If the protest cannot be resolved as specified in 120.57(3)(d)1, the standard of proof for any further proceedings shall be whether the proposed College action was clearly erroneous, contrary to competition, arbitrary or capricious. In any bid protest proceeding contesting all intended College action to reject all bids, the standard of review by any administrative law judge shall be whether the College's intended action is illegal, arbitrary, dishonest, or fraudulent.

END OF SECTION

SPECIFICATIONS

I. GENERAL REQUIREMENTS

Project tasks for Repaving of Parking Lot #11 call for, but are not limited to:

1. Bidders must submit a line itemized schedule of values and include their unit rates for fill dirt, stump removal, lime rock, earthwork, asphalt, wheel stops, drainage inlets and pipe.
2. The plan set states not for construction but is the current set. A final construction set will be issued prior to construction and will include updates regarding any addenda that are produced during the bid process. This is to avoid confusion regarding the correct final construction set.
3. The successful bidder agrees to comply with all applicable, federal, state and local laws, including but not limited to Davis-Bacon. Federal Contracting Requirements Addendum attached hereto.

II. CONTRACT TIME

Contractor shall begin work upon receipt of a Notice to Proceed issued by the Owner. All work shall be final and complete no later than thirty (30) calendar days after Notice to Proceed has been issued. Liquidated damages shall be \$500.00 per day. Work shall be permitted any time during the contract performance period. Any changes in the schedule start date or performance period must be agreed upon between the College and Contractor prior to commencement date. Please notify Owner of any long lead time items.

III. CONSTRUCTION AND MATERIALS

All construction methods and materials shall conform to the requirements of the Current Florida Building Code.

IV. QUALITY CONTROL AND ADMINISTRATIVE REQUIREMENTS

It is required that the Contractor contact college personnel or their designated representative to:

- a. Inspect that utilities have been protected or adjusted during construction.
- b. Approve any changes or deviations from the plans.
- c. Change Orders shall be approved in writing by the Owner for scope and cost before change work is performed. The Contractor shall be responsible for additional costs if change work is performed prior to a change order being approved in writing.

V. WARRANTY

Contractor shall provide Owner with a one (1) year warranty from the date of final completion.

VI. ATTACHMENTS TO THESE SPECIFICATIONS

Federal Contracting Requirements- Attachment No. 11

Davis Bacon Wages- Attachment No. 12

END OF SECTION

ATTACHMENT NO. 1
SUPPLEMENTARY CONDITIONS

1. **Conditions of the Contract** - The Instructions to Bidders, Specifications and these Supplementary Conditions are applicable to all aspects of this project, and it is the Contractor's responsibility to so inform all parties who should be influenced thereby.
2. **Liquidated Damages** – Bidders are notified that the following paragraphs concerning liquidated damages will be included in the Contract.

In as much as failure to complete the project work within the time herein fixed will result in substantial injury to the Owner, and whereas damages arising from such failure cannot be calculated with any degree of certainty, it is hereby agreed that if such work is not finally completed as herein defined within the time fixed for such performance of completion, the Contractor shall pay to the Owner, as liquidated damages for such delay and not as a penalty, the additional sum of \$500.00 each and every calendar day until final completion.

This provision for liquidated damages for delay shall in no manner affect the Owner's right to terminate the Contract as provided in the Contract Documents; and the Owner's exercise of the right to terminate shall not release the Successful Bidder from his/her obligation to pay said liquidated damages in the amounts indicated. Said liquidated damages shall be payable in addition to any excess expenses or costs payable by the Contractor and shall not exclude recovery of damages by the Owner under other provisions of the contract, except for the Contractor's delays.

3. **Notice to Owner** – If a Subcontractor or supplier files a Notice to Owner in any acceptable form under the Florida Mechanics Lien Law, the Owner will notify the Contractor of its receipt. Any payment request delivered subsequent to the receipt of that Notice to Owner that contains payment in full or in part for that Subcontractor or supplier shall require a Final or Partial Release of Lien from each Subcontractor or supplier so affected.
4. **Schedule of Values** – Prior to submitting its first application for payment for the Work, the Contractor shall prepare and present to the Owner and Professional for approval a schedule of values (SOV). The Contractor shall not imbalance or artificially inflate any element in the SOV. Upon the Owner's acceptance, the SOV shall be used to process and pay the Contractor's payment requests.
5. **Contractor's Liability Insurance**
 - a. The Contractor shall purchase and maintain in a company or companies licensed to do business in the State of Florida and acceptable to the Owner and his Insurance Counselor such insurance as will protect him from claims, some of which are set forth below, which may rise out of or result from the Contractor's operations under the Contract, whether such operations be by himself or by any Sub contractor or by anyone directly or indirectly employed by any of them, or by anyone else for whose acts any of them may be liable. The specific delineation of coverage in this paragraph is a minimum guide only, it being the specific intent of the Owner that it shall be fully and completely protected and indemnified from any and all claims which may arise out of Contractor's operation under the Contract; including among others those checked below:
 - 1) claims under workers' compensation, disability benefit and other similar employee benefit acts; or

- 2) claims for damages because of bodily injury, occupational sickness or disease, or death of his employees; or
 - 3) claims for damages because of bodily injury, sickness or disease, or death of any person other than his employees; or
 - 4) claims for damages by usual personal injury coverage including but not limited to libel, slander, and false arrest which are sustained (1) by any person including, but not limited to, a Contractor, Subcontractor or Sub subcontractor or their employees as a result of an occurrence directly or indirectly related to the employment of such person by the Contractor, or (2) by any other person; or
 - 5) claims for damages because of injury to or destruction of tangible property, including loss of use resulting therefrom; or
 - 6) claims resulting from explosion, collapse, or underground accident, (X C U coverage required) and other on premises operations; or
 - 7) claims resulting from owned, hired, and non-owned motor vehicles and equipment; or
 - 8) claims for damage resulting from the actions or inactions of independent Contractors; or
 - 9) claims arising under products and completed operations insurance.
- b. The insurance required by Subparagraph 6.a) shall be written for not less than the limits of liability specified below, or that required by law, whichever is greater, and shall include contractual liability insurance as applicable to the Contractor's obligations.

1) Workers' Compensation:

State per Chapter 440 F.S.	Statutory
Applicable Federal	Statutory
Employer's Liability	\$200,000

2) Comprehensive General Liability:

Including Premises Operations; Products Completed Operations; Contractor's Liability Broad Form Property Damage; Contractual Liability.

General Liability	\$1,000,000	Per Claimant
Property Damage	\$1,000,000	Per Occurrence
Personal Injury	\$1,000,000	Per Claimant
Liability	\$1,000,000	Per Occurrence
	\$2,000,000	Per Annual Aggregate

Property Damage Liability Insurance will provide X, C, or U coverage as applicable.

The Owner shall be named as additional insured on the Contractor's Comprehensive General Liability Policy.

Personal Injury Liability shall be separate coverage from Bodily Injury.

3) Owner's Protective Liability:

The Owner shall be named as the insured; ORIGINAL policy shall be submitted to the Owner.

Bodily/Personal	\$1,000,000	Per Claimant
Injury	\$1,000,000	Per Occurrence
Property Damage	\$1,000,000	Single Limit Per Occurrence

4) Contractor's Protective Liability:

The Owner shall be named as additional insured on the Contractor's Protective Liability Policy.

Bodily/Personal Injury	\$1,000,000	Per Occurrence
Property Damage	\$1,000,000	Single Limit Per Occurrence

5) Comprehensive Automobile Liability:

The Owner shall be named as additional insured on the Contractor's Comprehensive Automobile Liability Policy. Policy shall cover owned, hired and all classes of non-owned vehicles.

Bodily Personal Injury:	\$1,000,000	Per Occurrence
Property Damage:	\$1,000,000	Per Occurrence

6) Coverage to be certified by the Contractor (and Subcontractors) shall include, but not be limited to the following:

- Workers' Compensation
- Automobile owned, hired and non-owned
- Premises
- Operations
- Contractual
- Personal injury - Hazards, A, B and C with employee exclusion removed
- Broad Form Property Damage
- Removal of X, C and U exclusions
- Products and Completed Operations
- Independent Contractors

- c. A Certificate of Insurance (COI), executed on a standard ACORD form, shall be filed with the Owner simultaneously with the Contractor's execution of the Agreement. The certificate shall contain a provision that coverages afforded under the policies will not be cancelled until at least thirty (30) days prior written notice has been given to the Owner. The Certificate of Insurance will include the following statement: "Interest of the Certificate Holder is included as an Additional Insured."

6. Vendor Employee Requirements

- a. The Contractor shall be responsible to the Owner for the acts and omissions of all his employees and all Subcontractors, their agents and employees, and all other persons performing any of the work under a contract with the Contractor.
- b. The Contractor shall enforce strict discipline and good order among his employees.
- c. The College is committed to the education and safety of its students and employees. To that end, it is the Contractor's responsibility to ensure that all employees of the Contractor and all employees of the Subcontractors working with the Contractor adhere to the Jessica Lunsford Act (Florida Statute 1012.467).
- d. It is the Contractor's responsibility to ensure that all employees are legally allowed to work in the United States in accordance with immigration policies.
- e. The Contractor shall strictly prohibit interaction between their employees and students, faculty, and staff.

- f.** All employees assigned by the Contractor to the performance of work under contract shall be capable employees, age 18 years or above, qualified in this type of work and physically able to do their assigned work. It shall be the Contractor's responsibility to ensure that all employees meet the physical standards to perform the work assigned. This requirement also includes acceptable hygiene habits of Contractor's employees.
- g.** The Contractor's employees shall be required to dress neatly, appropriate with the tasks being performed.
- h.** Friends, visitors, or family members of the Contractor's employees are not permitted in the work area.
- i.** Any employee whose work performance or conduct is objectionable shall be immediately removed from the college premises at the request of the Owner. Such removal shall be by the Contractor.

END OF SECTION

ATTACHMENT NO. 2
AGREEMENT BETWEEN OWNER AND
CONTRACTOR

THIS AGREEMENT, made this _____ day of _____ in the year Two Thousand and _____ between the Owner: **THE DISTRICT BOARD OF TRUSTEES OF FLORIDA GATEWAY COLLEGE**, a body politic, whose mailing address is 149 S.E. College Place, Lake City, Florida 32025; and the Contractor: _____ whose mailing address is _____.

ARTICLE 1
THE CONTRACT DOCUMENTS AND ORDER OF PRECEDENCE

The Contract Documents form the Contract. The Contract represents the entire and integrated agreement between the parties hereto and supersedes all prior negotiations, representations, or agreements, either written or oral, and including the bidding documents.

1.1. The Contract Documents consist of the following:

- (a) The executed Agreement between Owner and Contractor
- (b) Instructions to Bidders (Bid Package ITB # RP-24-01-04) and Attachments thereto
- (c) Plans
- (d) Performance Bond
- (e) Addenda issued prior to execution of the Contract
- (f) Modifications issued after execution of the Contract
- (g) Proposal submitted by the Contractor and accepted by the Owner

1.2 In the event of inconsistencies, conflicts or discrepancies among the documents comprising the Agreement between Owner and Contractor, the documents shall govern in the following order of precedence:

- 1. Owner-approved Change Orders and written amendments or addenda to this Agreement between Owner and Contractor with those of later date having precedence over those of earlier date
- 2. The executed Agreement between Owner and Contractor
- 3. Instructions to Bidders (**Bid Package ITB # RP-24-01-04**) and Attachments thereto
- 4. Plans
- 5. Proposal submitted by the Contractor and accepted by the Owner and post-bid modifications, if any.

Among categories of documents having the same order of precedence, the term or provision that includes the latest date shall control. Information identified in one Contract Document and not identified in another shall not be considered a conflict or inconsistency.

ARTICLE 2
THE WORK

The Contractor shall perform all the Work required by the Contract Documents in accordance with the Specifications and Plans for **ITB # RP-24-01-04, REPAVING OF PARKING LOT #11, 149 SE COLLEGE PLACE,**

LAKE CITY, FL 32025, and shall fully execute the work described in the documents, working whatever schedule is required to complete the work in the time allotted, including overtime work and weekend work as required.

ARTICLE 3
TIME OF COMMENCEMENT AND COMPLETION

Contractor shall execute the Owner/Contractor Contract within seven (7) calendar days from date of receipt and return to the Owner for his execution, along with all required bonds and insurance certificates. Contractor shall begin work upon receipt of a Notice to Proceed issued by Owner.

All work shall be Finally Complete THIRTY (30) calendar days after Notice to Proceed has been issued.

Where delays are not justified under conditions in the Contract Documents, the Contractor and his Sureties shall be liable for and shall pay to the Owner liquidated damages as follows:

If the Project is not Finally Completed, in accordance with the requirements of the Contract Documents, the Contractor shall pay to the Owner as liquidated damages for such delay, and not as a penalty, Five Hundred Dollars per calendar day past Final Completion date.

ARTICLE 4
CONTRACT SUM

The Owner shall pay the Contractor for the performance of the Work, subject to additions and deductions by Change Orders as provided in the Contract Documents, in current funds, the Contract Sum of _____ DOLLARS (\$_____).

ARTICLE 5
PROGRESS, FINAL PAYMENTS, AND CONTRACTOR PAYMENT TO SUBCONTRACTORS

Upon Application for Payment submitted by the Contractor to the Owner, the Owner shall make progress payments on account of the Contract Sum and a final Payment to the Contractor as follows:

- 5.1** The period covered by each Application for Payment shall be one calendar month ending on the last day of the month.
- a.** Contractor shall present to the Owner an Application for Payment as specified in 5.1.f. Owner shall remit payment, less any contested amount, not later than the 25th business days after the date on which the payment request or invoice is stamped as received as provided in 218.74(1) F.S.
 - b.** The Owner may reject the payment request or invoice within 20 business days after the date on which the payment request or invoice is stamped as received as provided in 218.74(1) F.S. The rejection must be written and must specify the deficiency in the payment request or invoice and the action necessary to make the payment request or invoice proper.
 - c.** If a payment request or an invoice is rejected under 5.1.b. and the contractor submits a corrected payment request or invoice which corrects the deficiency specified in writing by the Owner, the corrected payment request or invoice must be paid or rejected not later than the 10th business day after the date the corrected payment request or invoice is stamped as received as provided in 218.74(1) F.S.

- d. If the Owner disputes a portion of a payment request or an invoice, the undisputed portion shall be paid timely, in accordance with 5.1.a.
- e. Each Application for Payment shall be based on the most recent schedule of values submitted by the Contractor. The schedule of values shall allocate the entire Contract Sum among the various portions of the Work. The schedule of values shall be prepared in such form and supported by such data to substantiate its accuracy as the Owner may require. This schedule, unless objected to by the Owner, shall be used as a basis for reviewing the Contractor's Application for Payment.
- f. Applications for Payment shall indicate the percentage of completion of each portion of the Work as of the end of the period covered by the Application for Payment.
- g. With each Application for Payment, Contractor shall include a Conditional Full or Partial Release of Lien, as applicable, from those subcontractors whose work is included in the Application for Payment.

5.2 Subject to other provisions of the Contract Documents, the amount of each progress payment shall be computed as follows:

- a. According to the Owner's best judgment, the Owner shall, within the time period set forth above, make a progress payment to the Contractor in the amount provided in such Certificate; provided such payment in addition to all previous payments does not exceed ninety-five percent (95%) of the portion of the Contract Sum properly allocable to labor, materials and equipment incorporated in the Work plus ninety-five percent (95%) of the Contract Sum properly allocable to materials and equipment not incorporated in the Work but delivered and suitably stored at the site or at a bonded location suitable to Owner when agreed upon by the parties in writing, up to five days prior to the date on which the Application for Payment is submitted. Storage on the campus does not constitute title passing to the Owner.
- b. Any progress payments defined in 5.2 a. of this Agreement shall be reduced by any amounts that are the subject of a good faith dispute, the subject of a claim brought pursuant to 255.05 Florida Statutes or otherwise the subject of a claim or demand by the Owner or Contractor.
- c. If the project is not completed and Finally Accepted by the Owner, liquidated damages for each calendar day of such delay will be assessed in accordance with the Contract Documents. The Contractor and his Sureties will be liable for and shall pay the Owner such amount. Any waiver of any part of this provision must be in a separate writing signed by the Owner. When the Final Closeout Documents have been reviewed and approved, Final Payment of the remaining FIVE PERCENT (5%) will be made upon Final Acceptance by the Board of Trustees.

5.3 The Application for Payment for the final payment under the contract shall include the following forms:

- a. Contractor's Affidavit to Owner stating that all lienors have been paid in full. If any Sub contractor, material man, fabricator or supplier fails or refuses to furnish a release or waiver in full, the prime Contractor will furnish an Indemnity Bond for release of lien to the Owner, or other collateral satisfactory to the Owner, to indemnify the Owner against any lien.
- b. Consent of Surety to Final Payment on appropriate A.I.A. Document or other form acceptable to the Owner.
- c. Contractor's Affidavit of Release of Liens on A.I.A. Documents G706 and G706A, or other forms acceptable to the Owner, certifying that the prime Contractor, all Subcontractors, all suppliers of materials and equipment, and all performers of work, labor or services on the project release or waive any lien against the Owner arising in the construction project.

- 5.4** Subcontractors, forty-five (45) days after satisfactory completion of their work on the Contractor's project, can invoice the Contractor for the remainder of unpaid work, including the full value of the retainage related to their work, less the value of any item contested in accordance with the terms and conditions of the construction Contract.
- a.** The Contractor shall require the Subcontractor to include a conditional release of lien and all appropriate warranties and closeout documentation with this final payment invoice to the Contractor.
 - b.** The Contractor must include this subcontractor payment request in the next Application for Payment in the pay application cycle to the Owner following the receipt of the subcontractor payment request, if deemed to be complete and in compliance with this section.
 - c.** When a Contractor receives payment from the Owner for labor, services, or materials furnished by subcontractors and suppliers hired by the Contractor, the Contractor shall remit payment due to those subcontractors and suppliers, less the value of any item contested in accordance with the terms and conditions of the construction Contract, within ten (10) days after the Contractor's receipt of payment.
- 5.5** Paragraphs 5.4 shall not be construed to create a contractual relationship of any kind between the Owner and a Subcontractor or Sub-subcontractor (et al.), or between any persons or entities other than the Owner and Contractor.

ARTICLE 6
MISCELLANEOUS PROVISIONS

- 6.1** Terms used in the Agreement which are defined in the Conditions of the Contract shall have the meanings designated in those Conditions.
- 6.2** The Contract Documents as listed in Article 1 shall constitute the entire Agreement between the Owner and the Contractor, except for Modifications issued after execution of this Agreement, and shall include any Alternates set forth herein. In the event of a conflict between the Plans, then specific provisions of the Plans shall control.
- 6.3** The Owner's representative is:
Mike Lee, Project Manager
Florida Gateway College
149 S.E. College Place
Lake City, Florida 32025-8703
(386) 754-4472
(386) 965-0590
- 6.4** The Contractor's representative is:

Name and Title:
Name of Company:
Address:
Telephone:
- 6.5** Neither the Owner's nor the Contractor's representative shall be changed without ten (10) days written notice to the other party.

- 6.6** Owner and Contractor, respectively, bind themselves, their partners, successors, assigns and legal representatives to the other party hereto and to the partners, successors, assigns and legal representatives of such other party with respect to all covenants, agreements, and obligations contained in the Contract as a whole without the written consent of the other. Any assignment without such consent shall be null, void, and without effect. Furthermore, the Contractor agrees that it will not assign this Agreement, or any of the Contractor's rights hereunder, and that the Contractor will not sublet the work or services hereunder or any part thereof, (except as specifically herein before recognized and permitted), to any other person, firm or corporation.
- 6.7** The Contract shall be governed by, and construed under, the laws of the State of Florida, without regard to its choice of law provisions and venue shall lie in the courts in Columbia County, Florida.
- 6.8** The Contractor represents and warrants that it has not employed or retained any company or person (other than a bona fide employee working solely for the Contractor) to solicit or secure this Agreement, and that it has not paid or agreed to pay any person, company, corporation, individual or firm (other than a bona fide employee working solely for the Contractor) any fee, commission, percentage, gift, or any other consideration contingent upon or resulting from the award or making of this Agreement.
- 6.9** Owner's performance and obligation to pay hereunder is contingent upon an annual appropriation by legislature.
- 6.10** The Contractor represents that it is not on the State of Florida's convicted vendor list for a public crime committed within the past thirty-six (36) months. The Contractor further warrants that it will neither utilize the services of, nor contract with, any supplier, subcontractor, or consultant in connection with this Project if the supplier, subcontractor, or consultant has been placed on the State of Florida's convicted vendor list within the past thirty-six (36) months.
- 6.11** This Contract represents the entire and integrated agreement between the Owner and the Contractor, and supersedes all prior negotiations, representations, or agreements, either written or oral, for the Project. This Contract may be amended only by written instruments signed by both the Owner and Contractor.
- 6.12** Contractor shall provide Owner and its representative's access to the Work in preparation and progress wherever located.
- 6.13** Until the Contract terminates, Contractor shall carry the insurance and performance bond described in the Contract Documents.
- 6.14** The Contract may be unilaterally terminated by the Owner for refusal by the Contractor to allow public access to all documents, papers, letters, or other material subject to the provisions of Chapter 119, Florida Statutes, and made or received by the Contractor in conjunction herewith.
- 6.15** To the extent that Contractor meets the definition of "Contractor" under Section 119.0701, Florida Statutes, in addition to other contract requirements provided by law, Contractor must comply with public records laws, including the following provisions of Section 119.0701, Florida Statutes:
1. Keep and maintain public records required by the public agency to perform the service.
 2. Upon request from the public agency's custodian of public records, provide the public agency with a copy of the requested records or allow the records to be inspected or copied within a

reasonable time at a cost that does not exceed the cost provided in this chapter or as otherwise provided by law.

3. Ensure that public records that are exempt or confidential and exempt from public records disclosure requirements are not disclosed except as authorized by law for the duration of the Contract term and following completion of the Contract if the Contractor does not transfer the records to the public agency.
4. Upon completion of the Contract, transfer, at no cost, to the public agency all public records in possession of the Contractor to keep and maintain public records required by the public agency to perform the service. If the Contractor transfers all public records to the public agency upon completion of the Contract, the Contractor shall destroy all public records that are exempt or confidential and exempt from public records disclosure requirements. If the Contractor keeps and maintains public records upon completion of the Contract, the Contractor shall meet all applicable requirements for retaining public records. All records stored electronically must be provided to the public agency, upon request from the public agency's custodian of public records, in a format that is compatible with the information technology systems of the public agency.
5. **IF THE CONTRACTOR HAS QUESTIONS REGARDING THE APPLICATION OF CHAPTER 119, FLORIDA STATUTES, TO THE CONTRACTOR'S DUTY TO PROVIDE PUBLIC RECORDS RELATING TO THIS CONTRACT, CONTACT THE CUSTODIAN OF PUBLIC RECORDS Cassandra Buckles at 386-754-4313, cassandra.buckles@fgc.edu, Ms. Cassandra Buckles, Human Resources and Equity Officer, Florida Gateway College, 149 SE College Place, Lake City, Florida 32025.**

- 6.16 This Agreement does not constitute a personal liability or responsibility of the members of the Board of Trustees or obligation of the Owner's Board of Trustees, officers, employees, or attorneys.

[SIGNATURE PAGE FOLLOWS]

IN WITNESS WHERE OF, the parties have affixed their signatures, effective on the date first written above.

THE DISTRICT BOARD OF TRUSTEES OF FLORIDA GATEWAY COLLEGE

Board Chair

Signature

Date

STATE OF FLORIDA COUNTY OF _____

The foregoing instrument was acknowledged before me, by means of [] physical presence or [] online notarization this ____ day of _____ 20 ____, by _____ who [] is personally known to me or [] has produced a Florida driver’s license as identification.

Notary Public, State of Florida

(NOTARIAL SEAL)

My Commission Expires: _____

CONTRACTOR

Name and Title

Signature

Date

STATE OF FLORIDA COUNTY OF _____

The foregoing instrument was acknowledged before me, by means of [] physical presence or [] online notarization this ____ day of _____ 20 ____, by _____ who [] is personally known to me or [] has produced a Florida driver’s license as identification.

Notary Public, State of Florida

(NOTARIAL SEAL)

My Commission Expires: _____

END OF SECTION

**ATTACHMENT NO. 3
BID PROPOSAL FORM**

(To be copied on Contractor's business letterhead)

TO: DISTRICT BOARD OF TRUSTEES OF
FLORIDA GATEWAY COLLEGE
149 S.E. COLLEGE PLACE
LAKE CITY, FL 32025-8703

PROJECT: **REPAVING OF PARKING LOT #11
LAKE CITY, FLORIDA
FGC BID NUMBER: RP-24-01-04**

The undersigned Contractor, (hereinafter called "Bidder"), proposes to furnish all labor and materials for the construction of the above referenced project, in full accordance with the Contract Documents for said project, for the following bid price (prices):

BASE BID: _____ DOLLARS (\$ _____)
(Insert dollar amount in text) (Insert dollar amount in numbers)

The undersigned agrees that if this Bid Proposal is accepted, construction of this project will begin within the time specified after award of the Contract, and shall be Finally Completed within the specified time, as evidenced by Bidders willingness to sign, and execute a Contract so stating.

The Bidder does hereby agrees that this Bid Proposal shall remain in full force and effect for a period of thirty (30) calendar days after the time of the opening of this Bid Proposal, and that the Bidder will not revoke nor cancel this Bid Proposal or withdraw from the competition within said thirty calendar day period; that in the event the Contract is awarded to this Bidder, Bidder will, within seven (7) calendar days after it is received, enter into a written Contract with the Owner in accordance with the accepted bid.

Acknowledgment is hereby made of receipt of the following Addenda issued during the bidding period:

ADDENDUM NO. _____ DATE: _____

ADDENDUM NO. _____ DATE: _____

ADDENDUM NO. _____ DATE: _____

ADDENDUM NO. _____ DATE: _____

IN WITNESS WHEREOF, the Bidder has hereunto set his signature and affixed his seal this _____ day of

_____, 20____, BY: _____
(Type Firm Name) (Seal)

(Type Name and Title of Authorized Principal)

(Signature of Authorized Principal)

(Type Contractor's License Number)

STATE OF FLORIDA COUNTY OF _____

The foregoing instrument was acknowledged before me, by means of [] physical presence or [] online notarization this ____ day of _____ 20 ____, by _____ who [] is personally known to me or [] has produced a Florida driver's license as identification.

Notary Public, State of Florida

(NOTARIAL SEAL)

My Commission Expires: _____

END OF SECTION

**ATTACHMENT NO. 4
LIST OF SUBCONTRACTORS**

This list is attached to and is an integral part of the Bid Proposal submitted by:

FIRM NAME: _____

ADDRESS: _____

The undersigned, hereinafter called "Bidder" lists below the names of Subcontractors who will perform the portions of the work included in the project. Subcontractors listed cannot be changed without the express written approval of the Owner.

Subcontractors not meeting the requirements listed below will be cause for rejection of that Subcontractor. The undersigned declares that they have fully investigated each Subcontractor listed and has in his files evidence that such Subcontractor is currently and appropriately licensed in the State of Florida and engaged successfully in his line of work for a minimum of one year prior to this Bid Date or longer if required by the Specifications for the specific section or trade, that he maintains a fully equipped organization capable technically and financially of performing the pertinent work and that he has made similar installations in a satisfactory manner. Subcontractors proposed for this project may, at the Owner's discretion, be required to submit references from previous project owners.

If Contractor lists himself as a sub-contractor, he must meet all the above requirements, including licenses and/or certifications for each trade for which he is listed.

Subsequent to execution of the Contract, Contractor will be required to submit copies of all Subcontractors' and, if applicable, the Contractor's occupational licenses and evidence of compliance with the above requirements.

<u>Division of Work</u>	<u>Subcontractor Name</u>
_____	_____
_____	_____
_____	_____
_____	_____

IN WITNESS WHEREOF, the Bidder has hereunto set his signature and affixed his seal this ____ day of

_____, 20 ____, BY: _____

(Type Firm Name)

(Seal)

(Type Name and Title of Authorized Principal)

(Signature of Authorized Principal)

END OF SECTION

**ATTACHMENT NO. 5
IDENTICAL TIE BIDS STATEMENT**

Whenever two or more bids that are equal in respect to price, quality and service are received by the College for the procurement of commodities or contractual services, a bid received from a business that certifies that it has implemented a drug-free workplace program shall be given preference in the award process. Established procedures for processing tie bids will be followed if none of the tied contractors have a drug-free workplace program. In order to have a drug-free workplace program, a business shall:

1. Publish a statement notifying employees that the unlawful manufacture, distribution, dispensing, possession, or use of a controlled substance is prohibited in the workplace and specifying the actions that will be taken against employees for violations of such prohibition.
2. Inform employees about the dangers of drug abuse in the workplace, the business' policy of maintaining a drug-free workplace, any available drug counseling, rehabilitation and employee assistance programs and the penalties that may be imposed upon employees for drug abuse violations.
3. Give each employee engaged in providing the commodities or contractual services that are under bid a copy of the statement-specified subsection 1. (above)
4. In the statement specified in subsection 1., notify the employees that, as a condition of working on the commodities or contractual services that are under bid the employee will abide by the terms of the statement and will notify the employer of any conviction of or plea of guilty or nolo contendere to any violations of Chapter 893 or of any controlled substance law of the United States or any state for a violation occurring in the workplace no later than five (5) days after such conviction.
5. Impose a sanction on or require the satisfactory participation in a drug abuse assistance or rehabilitation program if such is available in the employee's community by any employee who is so convicted.
6. Make a good-faith effort to continue to maintain a drug-free workplace through implementation of this section.

As the person authorized to sign the statement, I certify that this firm complies fully with the above requirements.

(Type Name of Firm) (Signature of Authorized Principal)

STATE OF FLORIDA COUNTY OF _____

The foregoing instrument was acknowledged before me, by means of [] physical presence or [] online notarization this ____ day of _____ 20 ____, by _____ who [] is personally known to me or [] has produced a Florida driver's license as identification.

Notary Public, State of Florida

(NOTARIAL SEAL)

My Commission Expires: _____

END OF SECTION

ATTACHMENT NO. 6
PUBLIC ENTITY CRIMES SWORN STATEMENT

**SWORN STATEMENT PURSUANT TO SECTION 287.133(3)(a),
FLORIDA STATUTES, ON PUBLIC ENTITY CRIMES**

THIS FORM MUST BE SIGNED AND SWORN TO IN THE PRESENCE OF A NOTARY PUBLIC OR OTHER OFFICIAL AUTHORIZED TO ADMINISTER OATHS.

1. This sworn statement is submitted to: The Board of Trustees of Florida Gateway College

by _____ for _____
(Print Individual's Name and Title) (Print Name of Entity Submitting Sworn Statement)

whose business address is _____ and (if applicable) its Federal Employer Identification Number (FEIN) is _____.

If the entity has no FEIN, include the Social Security Number of the individual signing this statement:
_____.

2. I understand that a "public entity crime" as defined in Paragraph 287.133(1)(g), Florida Statutes, means a violation of any state or federal law by a person with respect to and directly related to the transaction of business with any public entity or with an agency or political subdivision of any other state of the United States, including, but not limited to, any bid or contract for goods or services to be provided to any public entity or an agency or political subdivision of any other state of the United States and involving antitrust, fraud, theft, bribery, collusion, racketeering, conspiracy, or material misrepresentation.
3. I understand that "convicted" or "conviction" as defined in Paragraph 287.133(1)(b) Florida Statutes, means a finding of guilt or a conviction of a public entity crime, with or without an adjudication of guilt, in any federal or state trial court of record relating to charges brought by indictment or information after July 1, 1989, as a result of a jury verdict, non-jury trial, or entry of plea of guilty or nolo contendere.
4. I understand that an "affiliate" as defined in Paragraph 287.133(1)(a) Florida Statutes, means:
 - a. A predecessor or successor of a person convicted of a public entity crime; or
 - b. An entity under the control of any natural person who is active in the management of the entity and who has been convicted of a public entity crime. The term "affiliate": includes those officers, directors, executives, partners, shareholders, employees, members, and agents who are active in the management of an affiliate. The ownership by one person of shares constituting a controlling interest in another person or pooling of equipment or income among persons when not for fair market value under an arm's length agreement, shall be a prima facie case that one person controls another person. A person who knowingly enters into a joint venture with a person who has been convicted of a public entity crime in Florida during the preceding 36 months shall be considered an affiliate.
5. I understand that a "person" as defined in Paragraph 287.133(1)(e), Florida Statutes, means any natural person or entity organized under the laws of any state or of the United States with the legal power to enter into a binding contract and which bids or applies to bid on contracts for the provision

of goods or services let by a public entity, or which otherwise transacts or applies to transact business with a public entity. The term "person" includes those officers, directors, executives, partners, shareholders, employees, members, and agents who are active in management of an entity.

- 6. Based on information and belief, the statement, which I have marked below, is true in relation to the entity submitting this sworn statement. (Please indicate which statement applies).

_____ Neither the entity submitting this sworn statement, nor any of its officers, directors, executives, partners, shareholders, employees, members, or agents who are active in the management of the entity, nor the affiliate of the entity has been charged with and convicted of a public entity crime subsequent to July 1, 1989.

_____ The entity submitting this sworn statement, or one or more of its officers, directors, executives, partners, shareholders, employees, members, or agents who are active in the management of the entity, or an affiliate of the entity has been charged with and convicted of a public entity crime subsequent to July 1, 1989.

_____ The entity submitting this sworn statement, or one or more of its officers, directors, executives, partners, shareholders, employees, members, or agents who are active in the management of the entity, or an affiliate of the entity has been charged with and convicted of a public entity crime subsequent to July 1, 1989. However, there has been a subsequent proceeding before a Hearing Officer of the State of Florida, division of Administrative Hearings and the Final Order entered by the Hearing Officer determined that it was not in the public interest to place the entity submitting this sworn statement on the convicted vendor list (attach a copy of the final order).

I UNDERSTAND THAT THE SUBMISSION OF THIS FORM TO THE CONTRACTING OFFICER FOR THE PUBLIC ENTITY IDENTIFIED IN PARAGRAPH 1 (ONE) ABOVE IS FOR THAT PUBLIC ENTITY ONLY AND, THAT THIS FORM IS VALID THROUGH THE LIFE OF THE CONTRACT. I ALSO UNDERSTAND THAT I AM REQUIRED TO INFORM THE PUBLIC ENTITY PRIOR TO ENTERING INTO A CONTRACT IN EXCESS OF THE THRESHOLD AMOUNT PROVIDED IN SECTION 287.017, FLORIDA STATUTES FOR CATEGORY TWO OF ANY CHANGE IN THE INFORMATION CONTAINED IN THIS FORM.

Signature

Date

STATE OF FLORIDA COUNTY OF _____

The foregoing instrument was acknowledged before me, by means of [] physical presence or [] online notarization this ____ day of _____ 20 ____, by _____ who [] is personally known to me or [] has produced a Florida driver's license as identification.

Notary Public, State of Florida

(NOTARIAL SEAL)

My Commission Expires: _____

END OF SECTION

ATTACHMENT NO. 7
APPLICATION AND CERTIFICATE FOR PAYMENT

(THIS FORM SHALL BE USED WITHOUT CHANGES)

Date: _____ For Period Ending: _____ Payment No.: _____

CONTRACTOR: _____

CONTRACT FOR: ITB # RP-24-01-04
 REPAVING OF PARKING LOT #11
 LAKE CITY, FLORIDA

Original Contract Sum	\$ _____	Contract Time	_____	Calendar Days	_____
Adds to Date	\$ _____	Authorized Ex	_____	Calendar Days	_____
Total	\$ _____	Pending Requests	_____	Calendar Days	_____
Deducts to Date	\$ _____	Time Lapsed to Date	_____	Calendar Days	_____
Adj. Contract Sum	\$ _____				

WORK PERFORMED TO DATE	\$ _____
MATERIAL SUITABLY STORED (Itemized list of materials attached).	\$ _____
TOTAL TO DATE	\$ _____
Less Retainage (5%)	\$ _____
Less Previous Payments	\$ _____
Total	\$ _____
DUE THIS PAYMENT	\$ _____

CERTIFICATION OF THE CONTRACTOR: According to the best of my knowledge and belief, I certify that all items and amounts shown on the face of this Certificate are correct and that all work has been performed and material supplied in full accordance with the terms and conditions of the Contract. I further certify that all just and lawful bills against the undersigned and his subcontractors have been paid in full accordance with their terms and conditions and that **all subcontractors listed on the previous month's Application and Certificate for Payment have been paid the full amount listed on that Application.**

Date: _____ Contractor: _____

STATE OF FLORIDA COUNTY OF _____

The foregoing instrument was acknowledged before me, by means of [] physical presence or [] online notarization this ____ day of _____ 20 ____, by _____ who [] is personally known to me or [] has produced a Florida driver's license as identification.

Notary Public, State of Florida

(NOTARIAL SEAL)

My Commission Expires: _____

CERTIFICATE OF THE DIRECTOR OF FACILITIES: I certify that I have checked and verified this Certificate; that to the best of my knowledge and belief it is a true statement of the value of the Work performed and material suitably stored on the site or other approved location by the Contractor; that all work and material included in this Certificate have been reviewed by me or my authorized Representative; and that all work has been performed and material supplied in full accordance with the terms of the Contract.

Date: _____

Director of Facilities Signature: _____

APPROVED FOR PAYMENT:

Date: _____

VP of Business Services: _____

END OF SECTION

**ATTACHMENT NO. 8
PERFORMANCE BOND**

THIS BOND IS ISSUED IN FAVOR OF THE OWNER CONDITIONED ON THE FULL AND FAITHFUL PERFORMANCE OF THE CONTRACT AS PROVIDED BY SECTION 255.05, F.S.

KNOW ALL MEN BY THESE PRESENTS: that (Contractor name & address), as Principal, hereinafter called Contractor and (Surety name, address & phone number), as surety, hereinafter called Surety, are held and firmly bound unto the **DISTRICT BOARD OF TRUSTEES OF FLORIDA GATEWAY COLLEGE**, as Obligee, hereinafter called Owner, for the use and benefit of claimants as herein below defined, in the amount of (contract amount), for the payment where of Contractor and Surety bind themselves, their heirs, executors, administrators, successors and assigns, jointly and severally, firmly by these presents.

WHEREAS, Contractor has by written agreement dated _____ 20 ____, entered into a contract with Owner for college walkway improvements, project No. RR-24-01-04, in accordance with the plans and specifications which contract is by reference made a part hereof and is hereinafter referred to as the Contract.

NOW, THEREFORE, THE CONDITION OF THIS OBLIGATION is such that, if Contractor shall promptly and faithfully perform said Contract and all obligations thereunder, then this obligation shall be null and void; otherwise, it shall remain in full force and effect. The Surety hereby waives notice of any alteration or extension of time made by the Owner, and any changes in or under the contract documents and compliance or non-compliance with any formalities connected with the contract which shall not affect Surety's obligation under this bond.

NOW, THEREFORE, THE CONDITION OF THIS OBLIGATION is that if Contractor:

1. Performs the Contract between Contractor and Owner, and at the times and in the manner prescribed in the Contract; and
2. Promptly makes payments to all claimants, as defined in Section 255.05(1), Florida Statutes, supplying Contractor with labor, materials, or supplies used directly or indirectly by Contractor in the prosecution of the work provided for in the Contract; and
3. Pays Owner all losses, damages, expenses, costs, and attorneys' fees, including appellate proceedings, that Owner sustains because of a default by Contractor under the Contract; and
4. Performs the guarantee of all work and materials furnished under the Contract for the time specified in the Contract, then this bond is void. Otherwise, it remains in full force.

The sole and exclusive venue and jurisdiction for any proceedings, legal or equitable, under this Bond, shall be in a court of competent jurisdiction in the county in which the project which is the subject of this Bond is being constructed.

Any action instituted by a claimant under this bond for payment must be in accordance with the notice and time limitation provisions in Section 255.05(2), Florida Statutes.

Any changes in or under the Contract documents and compliance or non-compliance with formalities connected with the Contract or the changes does not affect Surety's obligation under this bond.

SIGNED AND SEALED THIS _____ DAY OF _____, 20_____.

***** CONTRACTOR *****

(As Witnessed By) (Contractor Name) (Seal)

(Printed Name and Title)

***** SURETY *****

(As Witnessed By) (Surety Name) (Seal)

(Printed Name and Title)

(Address)

(Power of Attorney attached hereto)

END OF SECTION

ATTACHMENT NO. 9
FGC DROPBOX SUBMITTAL INSTRUCTIONS

**Submitting Bid Proposals
via FGC Dropbox Instructions**

STEP 1. In a web browser, navigate to <https://dropbox.fgc.edu/>.

STEP 2. Click the **Drop-off** button.

 **FLORIDA GATEWAY COLLEGE**

Home Login

Florida Gateway College Username: Password: Login

If you are a Florida Gateway College user, you should login above to avoid having to verify your email address, and be able to drop-off files to non-Florida Gateway College users.

Anyone may perform the following activities:

Drop-off Drop-off (*upload*) a file for a Florida Gateway College user (**email verification required**).

Pick-up Pick-up (*download*) a file dropped off for you.

i Florida Gateway College users: you may login with your username and password and send files to anyone, in or out of College.
Non-Florida Gateway College users: you cannot log in, but can still send files to Florida Gateway College users if you know their email address. Start by clicking the "Drop-off" button.
Florida Gateway College users who wish someone outside College to send them files, can make it a lot easier for them by logging in and clicking "Request a Drop-off". That saves the other person having to prove who they are. The request created will be valid for 7 days.

FGC Dropbox is a service to make it easy for you to move files, including large files up to 20.0 GB, in and out of College.

? How secure is FGC Dropbox?

i Files are automatically deleted from FGC Dropbox 14 days after you upload them.

Version 5.03 | Copyright © 2018 ZendTo | [About FGC Dropbox](#)
This service is powered by a copy of ZendTo

STEP 3.

On the page that follows enter:

- 1) enter your name, organization, and email address
- 2) complete the reCAPTCHA
- 3) click the **Send confirmation** button

The screenshot shows a web form for Florida Gateway College. At the top right is the college's logo and name. A blue 'Home' button is on the left. The form is titled 'Information about the Sender'. It asks 'Have you been given a "Request Code"?' with 'Yes' and 'No' buttons. A red box labeled '1)' highlights three input fields: 'Your name: [text box] (required)', 'Your organization: [text box]', and 'Your email address: [text box] (required)'. Below this, it says 'To confirm that you are a real person (and not a computer), please complete the quick challenge below:'. A red box labeled '2)' highlights a reCAPTCHA widget with the text 'I'm not a robot' and a 'reCAPTCHA' logo with links for 'Privacy' and 'Terms'. Below the widget, it says 'I now need to send you a confirmation email. When you get it in a minute or two, click on the link in it.' A red box labeled '3)' highlights a blue 'Send confirmation' button. At the bottom, it says 'Version 5.03 | Copyright © 2018 ZendTo | About FGC Dropbox This service is powered by a copy of ZendTo'.

STEP 4. You will receive an email like the one below at the address you specified in the previous step. Navigate to the link provided in the email.

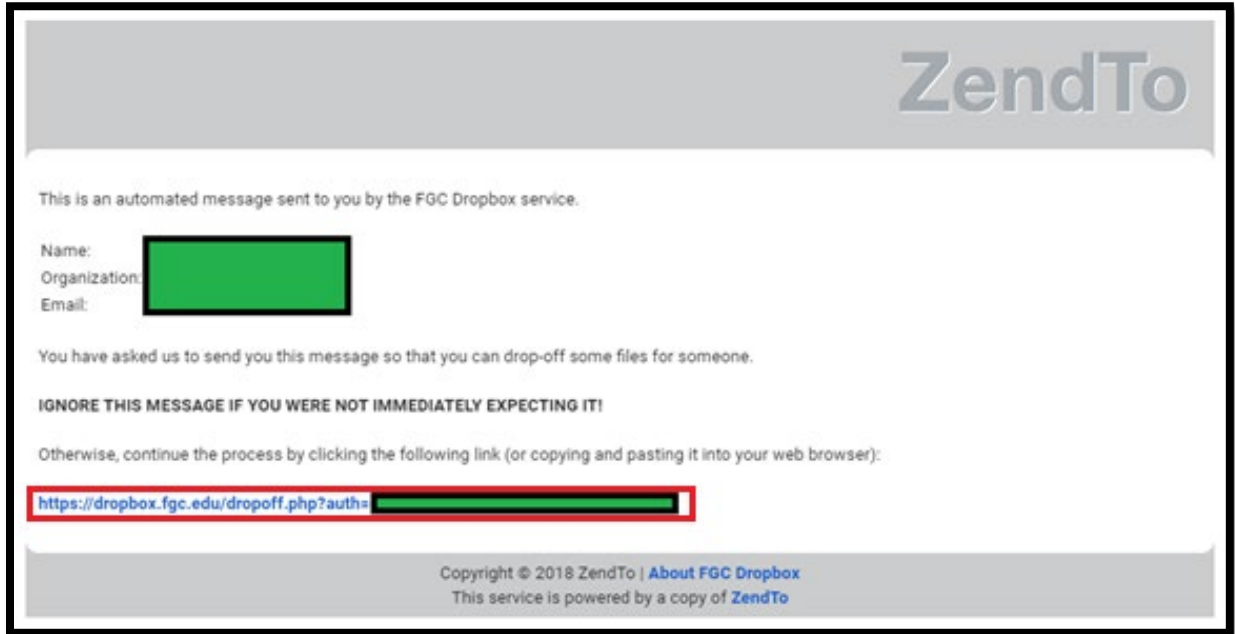

STEP 5.

On the linked page:

- 1) click the add button (green and white plus sign)
- 2) enter the recipient's information

Name: Kathrine Harris

Email: kathrine.harris@fgc.edu

- 3) click the **Add Recipient** button
- 4) click the close button on the Add Recipients modal dialog.

FLORIDA GATEWAY COLLEGE

Add Recipients

Name:

Email:

1)

2)

3)

4)

PLEASE NOTE

Files uploaded to FGC Dropbox are scanned for malware. Users are also strongly encouraged to avoid uploading sensitive information as you would with any other file you upload (e.g. personal private information)!

This web page will allow you to drop-off (upload) files containing the information you enter below for identity confirmation purposes.

From:

Encrypt every file

Calculate SHA-256 checksum of each file

Send an email to me when each recipient picks up the file(s)

To:

Send e-mail message to recipients which includes Passcode as well as Claim ID

Short note to the Recipients:

1000 / 1000 left

Version 5.03 | Copyright © 2018 ZendTo | About FGC Dropbox
This service is powered by a copy of ZendTo

STEP 6. **IMPORTANT:** To provide assurance that the submitted files cannot be opened except by College personnel at the appropriate time:

- 1) check the **Encrypt every file** checkbox
- 2) carefully enter a secure passphrase
- 3) click the **OK** button.

You **MUST** email the passphrase to kathrine.harris@fgc.edu. Without the passphrase, the files **CANNOT** be retrieved, even by College IT staff.

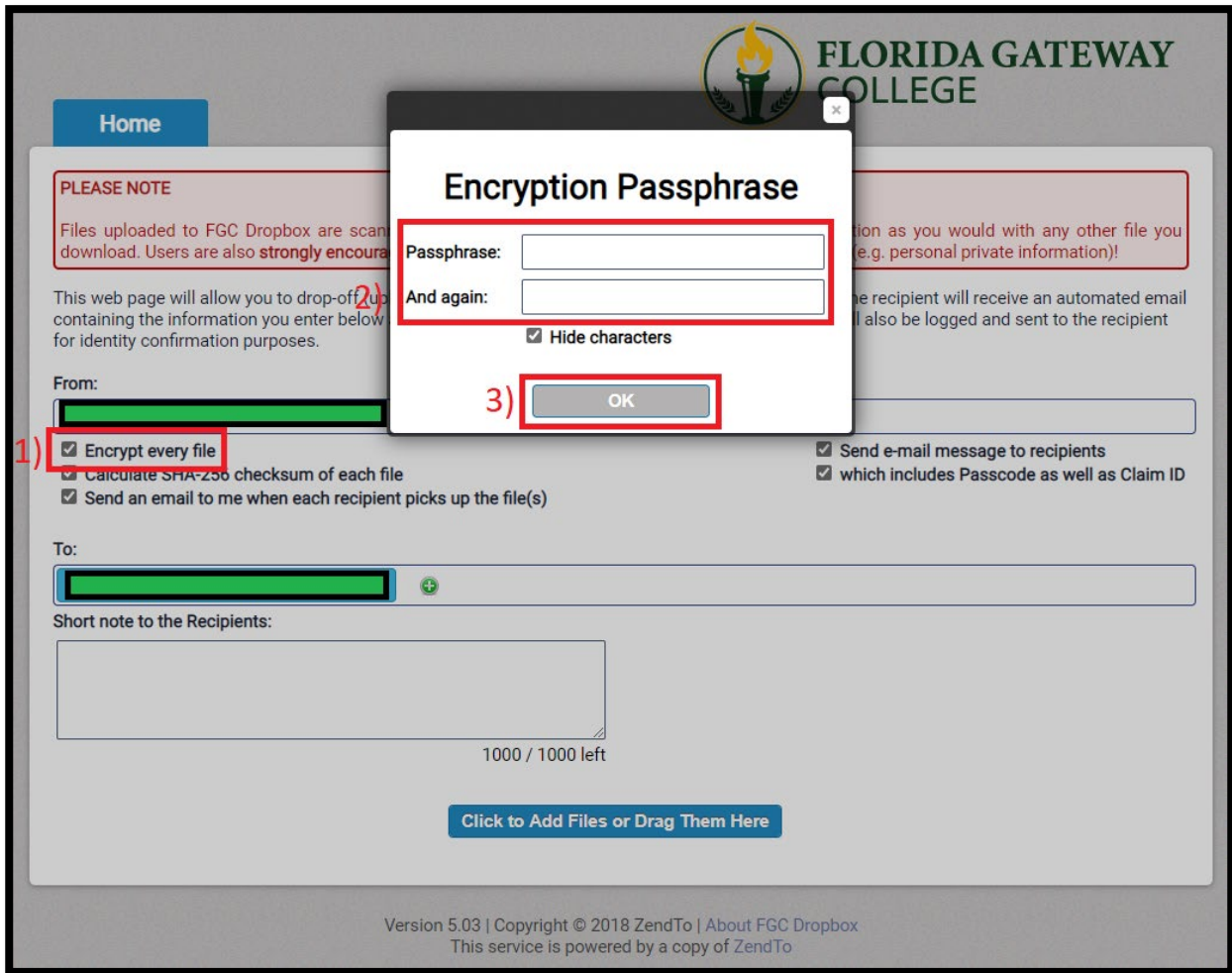

Step 7. Upload the desired file(s) to be submitted. Either drag-and-drop the file(s) into the browser window or click the **Click to Add Files or Drag Them Here** button and select the file(s) from the dialog window that opens.

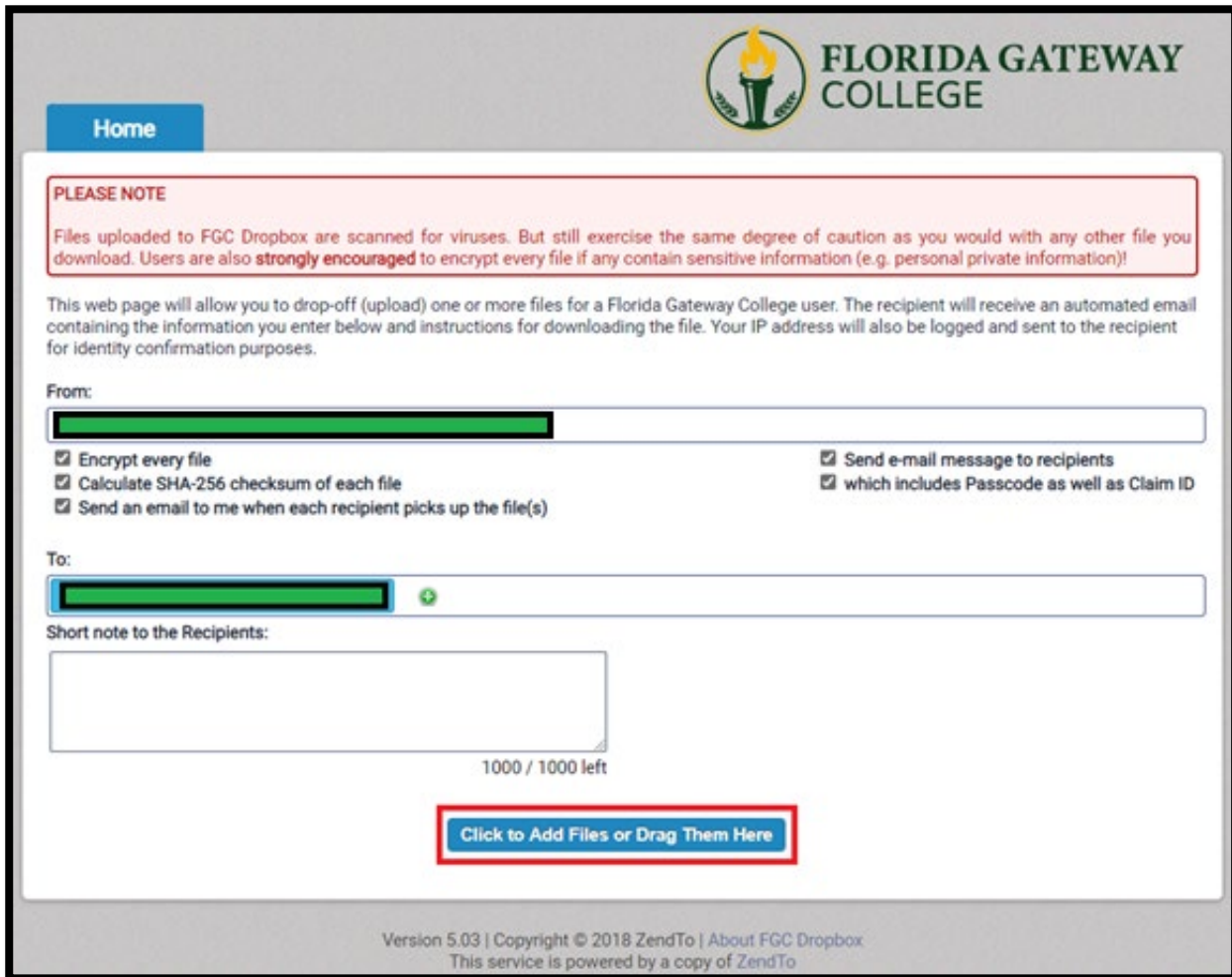

The screenshot shows the Florida Gateway College FGC Dropbox upload page. At the top right is the Florida Gateway College logo. A blue 'Home' button is on the left. A red-bordered box contains a 'PLEASE NOTE' section with text about virus scanning and encryption. Below this is a paragraph explaining the upload process. The form includes a 'From:' field with a green bar, a 'To:' field with a green bar and a plus icon, and a 'Short note to the Recipients:' text area with a '1000 / 1000 left' character count. A blue button with a red border is labeled 'Click to Add Files or Drag Them Here'. The footer contains version and copyright information.

Home

FLORIDA GATEWAY COLLEGE

PLEASE NOTE

Files uploaded to FGC Dropbox are scanned for viruses. But still exercise the same degree of caution as you would with any other file you download. Users are also **strongly encouraged** to encrypt every file if any contain sensitive information (e.g. personal private information)!

This web page will allow you to drop-off (upload) one or more files for a Florida Gateway College user. The recipient will receive an automated email containing the information you enter below and instructions for downloading the file. Your IP address will also be logged and sent to the recipient for identity confirmation purposes.

From:

[Redacted]

Encrypt every file Send e-mail message to recipients
 Calculate SHA-256 checksum of each file which includes Passcode as well as Claim ID
 Send an email to me when each recipient picks up the file(s)

To:

[Redacted] +

Short note to the Recipients:

[Text Area]

1000 / 1000 left

Click to Add Files or Drag Them Here

Version 5.03 | Copyright © 2018 ZendTo | About FGC Dropbox
This service is powered by a copy of ZendTo

Step 8. After uploading your files:

- 1) Enter a brief description of each item.
- 2) Type your organization's name and ITB # RR-24-1-02 RE-ROOFING OF MULTI-USE FACILITY

When done:

- 3) click the **Drop-off Files** button to submit your files.

The screenshot shows the Florida Gateway College Dropbox interface. At the top right is the college logo and name. A 'Home' button is on the left. A 'PLEASE NOTE' box contains a warning about virus scanning and encryption. Below this is an explanatory paragraph. The 'From:' field is filled with a redacted name. There are four checkboxes: 'Encrypt every file', 'Calculate SHA-256 checksum of each file', 'Send an email to me when each recipient picks up the file(s)', 'Send e-mail message to recipients', and 'which includes Passcode as well as Claim ID'. The 'To:' field is also redacted. A 'Short note to the Recipients:' text area contains 'This is an example note.' and is annotated with a red box and '2)'. Below the note is a 'Click to Add Files or Drag Them Here' button. A table lists a file 'ExampleFile.txt' with size '<0.1 KB' and a description 'Example file description', which is annotated with a red box and '1)'. Below the table is a 'Drop-off Files' button, annotated with a red box and '3)'. The footer contains version and copyright information.

FLORIDA GATEWAY COLLEGE

Home

PLEASE NOTE

Files uploaded to FGC Dropbox are scanned for viruses. But still exercise the same degree of caution as you would with any other file you download. Users are also **strongly encouraged** to encrypt every file if any contain sensitive information (e.g. personal private information)!

This web page will allow you to drop-off (upload) one or more files for a Florida Gateway College user. The recipient will receive an automated email containing the information you enter below and instructions for downloading the file. Your IP address will also be logged and sent to the recipient for identity confirmation purposes.

From:

[Redacted]

Encrypt every file Send e-mail message to recipients
 Calculate SHA-256 checksum of each file which includes Passcode as well as Claim ID
 Send an email to me when each recipient picks up the file(s)

To:

[Redacted]

Short note to the Recipients:

This is an example note.

976 / 1000 left

2)

Click to Add Files or Drag Them Here

Filename	Size	Description
1: ExampleFile.txt	<0.1 KB	Example file description

<0.1 KB / 20480 MB

3) Drop-off Files

Version 5.03 | Copyright © 2018 ZendTo | About FGC Dropbox
This service is powered by a copy of ZendTo

Step 9. You will then be presented with the Drop-Off Summary.

Home

FLORIDA GATEWAY COLLEGE

Drop-Off Summary

Your files have been sent successfully.

This drop-off is encrypted with a passphrase known only to the sender.

Filename	Size	SHA-256 Checksum	Description
ExampleFile.txt	16 bytes	42319A509CF5DFFB1E14E6D4C8D33180 7B64750DFBBCE6AB9EA7C7FAE1639CB4	Example file description

1 file

From: from on 2020-04-02 13:26

Comments:

This is an example note.

Version 5.03 | Copyright © 2018 ZendTo | [About FGC Dropbox](#)
This service is powered by a copy of ZendTo

END OF SECTION

**ATTACHMENT NO. 10
BIDDERS CHECKLIST**

To assist you in furnishing a responsible bid, this sample checklist has been prepared for your use, prior to bid submittal. The documents listed below must be submitted with the bid proposal.

	Attachment 3 – Bid Proposal Form (Mandatory)
	Attachment 4 – List of Subcontractors (Mandatory)
	Attachment 5 – Identical Tie Bids Statement (Non-Mandatory)
	Attachment 6 – Public Entity Crimes Sworn Statement (Mandatory)

END OF SECTION

ATTACHMENT NO. 11
FEDERAL CONTRACTING REQUIREMENTS
ADDENDUM

FEDERAL CONTRACTING REQUIREMENTS ADDENDUM

The District Board of Trustees for Florida Gateway College (“the Board”), and _____ (“Contractor”), having entered into an agreement dated the ____ day of _____, 2024, (hereinafter “the Agreement”) which will be funded wholly or in part with federal funding. As such, federal laws, regulations, policies and related administrative practices apply to this Agreement. Contractor agrees to comply with all federal, state and local laws, regulations and rules as amended from time to time, including those required by Appendix II to 2 CFR §200.327 as set forth below, as applicable:

A) ADMINISTRATIVE, CONTRACTUAL OR LEGAL REMEDIES FOR VIOLATIONS OR BREACH OF CONTRACT

Administrative, contractual or legal remedies for violations of breach of contract terms for contracts for more than the simplified acquisition threshold, are addressed within the Agreement.

B) TERMINATION FOR CAUSE AND FOR CONVENIENCE.

This clause applies to all contracts in excess of \$10,000.

In addition to the termination for cause set forth within the Parties’ agreement, the Board may, at any time and without cause, terminate Contractor’s services and work at the Board’s convenience by providing written notice to Contractor. Upon receipt of such notice, Contractor shall, unless the notice directs otherwise, immediately discontinue work and placing of orders for materials, facilities and supplies in connection with the performance of this Agreement. at any time for its sole convenience and without any fault on the part of Contractor.

Upon such termination, Contractor shall be entitled to payment only as follows: (1) the actual cost of the work completed in conformity with the Agreement, plus (2) such other costs actually incurred by Contractor as are permitted by the prime contract and approved by the Board; (3) plus ten percent (10% of the cost of the work referred to in subparagraph (1) above for overhead and profit. There shall be deducted from such sums as provided in this subparagraph the amount of any payments made to Contractor prior to the date of the termination of this Agreement. Contractor shall not be entitled to any claim or claim of lien against Owner for any additional compensation or damages in the event of such termination and payment.

C) EQUAL EMPLOYMENT OPPORTUNITY

During the performance of this contract, the Contractor agrees as follows:

1. The Contractor will not discriminate against any employee or applicant for employment because of race, color, religion, sex, or national origin. The Contractor will take affirmative action to ensure that applicants are employed, and that employees are treated during employment without regard to their race, color, religion, sex, or national origin. Such action shall include, but not be limited to the following:

Employment, upgrading, demotion, or transfer; recruitment or recruitment advertising; layoff or termination; rates of pay or other forms of compensation; and selection for training, including apprenticeship. The Contractor agrees to post in conspicuous places, available to employees and applicants for employment, notices to be provided setting forth the provisions of this nondiscrimination clause.

2. The Contractor will, in all solicitations or advertisements for employees placed by or on behalf of the Contractor, state that all qualified applicants will receive considerations for employment without regard to race, color, religion, sex, or national origin.
3. The Contractor will not discharge or in any other manner discriminate against any employee or applicant for employment because such employee or applicant has inquired about, discussed, or disclosed the compensation of the employee or applicant or another employee or applicant. This provision shall not apply to instances in which an employee who has access to the compensation information of other employees or applicants as part of the employee's essential job functions discloses the compensation of such other employees or applicants to individuals who do not otherwise have access to such information, unless such disclosure is in response to a formal complaint or charge, in furtherance of an investigation, proceeding, hearing, or action, including an investigation conducted by the employer, or is consistent with the contractor's legal duty to furnish information.
4. The Contractor will send to each labor union or representative of workers with which he has a collective bargaining agreement or other contract or understanding, a notice to be provided advising the said labor union or workers' representatives of the Contractor's commitments under this section and shall post copies of the notice in conspicuous places available to employees and applicants for employment.

5. The Contractor will comply with all provisions of Executive Order 11246 of September 24, 1965, as amended by executive Order 11375, and with the rules, regulations, and relevant orders of the Secretary of Labor.
6. The Contractor will furnish all information and reports required by Executive Order 11246 of September 24, 1965, and by rules, regulations, and orders of the Secretary of Labor, or pursuant thereto, and will permit access to his books, records, and accounts by the administering agency and the Secretary of Labor for purposes of investigation to ascertain compliance with such rules, regulations, and orders.
7. In the event of the Contractor's noncompliance with the nondiscrimination clauses of this contract or with any of the said rules, regulations, or orders, this contract may be canceled, terminated, or suspended in whole or in part and the Contractor may be declared ineligible for further Government contracts or federally assisted construction contracts in accordance with procedures authorized in Executive Order 11246 of September 24, 1965, and such other sanctions as may be imposed and remedies invoked as provided in Executive Order 11246 of September 24, 1965, or by rule, regulation, or order of the Secretary of Labor, or as otherwise provided by law.
8. The Contractor will include the portion of the sentence immediately preceding paragraph (1) and the provisions of paragraphs (1) through (7) in every subcontract or purchase order unless exempted by rules, regulations, or orders of the Secretary of Labor issued pursuant to section 204 of Executive Order 11246 of September 24, 1965, so that such provisions will be binding upon each subcontractor or vendor. The Contractor will take such action with respect to any subcontract or purchase order as the administering agency may direct as a means of enforcing such provisions, including sanctions for noncompliance: Provided, however, that in the event a Contractor becomes involved in, or is threatened with, litigation with a subcontractor or vendor as a result of such direction by the administering agency the Contractor may request the United States to enter into such litigation to protect the interests of the United States.

D) DAVIS BACON, AS AMENDED (40 U.S.C. 3141-3148)

- (1) Minimum wages.
 - (i) All laborers and mechanics employed or working upon the site of the work (or under the United States Housing Act of 1937 or under the Housing Act of 1949 in the construction or development of the project), will be paid unconditionally and not less often than once a week, and without subsequent deduction or rebate on any account (except such payroll deductions as are permitted by regulations issued by the Secretary of Labor under the Copeland Act (29 CFR

part 3)), the full amount of wages and bona fide fringe benefits (or cash equivalents thereof) due at time of payment computed at rates not less than those contained in the wage determination of the Secretary of Labor which is attached hereto and made a part hereof, regardless of any contractual relationship which may be alleged to exist between the contractor and such laborers and mechanics. Contributions made or costs reasonably anticipated for bona fide fringe benefits under section 1(b)(2) of the Davis-Bacon Act on behalf of laborers or mechanics are considered wages paid to such laborers or mechanics subject to the provision of paragraph (a)(1)(iv) of this section; also, regular contributions made or costs incurred for more than a weekly period (but not less often than quarterly) under plans, funds, or programs which over the particular weekly period, are deemed to be constructively made or incurred during such weekly period. Such laborers and mechanics shall be paid the appropriate wage rate and fringe benefits not the wage determination for the classification of work actually performed, without regard to skill, except as provided in § 5.5(a)(4). Laborers or mechanics performing work in more than one classification may be compensated at the rate specified for each classification for the time actually worked therein: Provided, that the employer's payroll records accurately set forth the time spent in each classification in which work is performed. The wage determination (including any additional classification and wage rates conformed under paragraph (a)(1)(ii) of this section) and the Davis-Bacon poster (WH-1321) shall be posted at all times by the contractor and its subcontractors at the site of the work in a prominent and accessible place where it can be easily seen by the workers.

(ii)

(A) The contracting officer shall require that any class of laborers or mechanics, including helpers, which is not listed in the wage determination and which is to be employed under the contract shall be classified in conformance with the wage determination. The contracting officers shall approve an additional classification and wage rate and fringe benefits therefore only when the following criteria have been met:

- (1) The work to be performed by the classification requested is not performed by a classification in the wage determination; and
- (2) The classification is utilized in the area by the construction industry' and
- (3) The proposed wage rate, including any bona fide fringe benefits, bears a reasonable relationship to

the wage rates contained in the wage determination

- (B) If the contractor and the laborers and mechanics to be employed in the classification (if known), or their representatives, and the contracting officer agree on the classification and wage rate (including the amount designated for fringe benefits where appropriate), a report of the action taken shall be sent by the contracting officer to the Administrator of the Wage and Hour Division, U.S. Department of Labor, Washington, DC 20210. The Administrator, or an authorized representative, will approve, modify, or disapprove every additional classification action within 30 days of receipt and so advise the contracting officer or will notify the contracting officer within the 30-day period that additional time is necessary.
 - (C) In the event the contractor, the laborers or mechanics to be employed in the classification or their representatives, and the contracting officer do not agree on the proposed classification and wage rate (including the amount designated for fringe benefits, where appropriate), the contracting officer shall refer the questions, including the views of all interested parties and the recommendation of the contracting officer, to the Administrator for determination. The Administrator, or an authorized representative, will issue a determination within 30 days of receipt and so advise the contracting officer or will notify the contracting officer within the 30-day period that additional time is necessary.
 - (D) The wage rate (including fringe benefits where appropriate) determined pursuant to paragraphs (a)(1)(ii) (B) or (C) of this section, shall be paid to all workers performing work in the classification under this contract from the first day on which work is performed in the classification.
- (iii) Whenever the minimum wage rate prescribed in the contract for a class of laborers or mechanics includes a fringe benefit which is not expressed as an hourly rate, the contractor shall either pay the benefit as stated in the wage determination or shall pay another bona fide fringe benefit or an hourly cash equivalent thereof.
 - (iv) If the contractor does not make payments to a trustee or other third person, the contractor may consider as part of the wages of any laborer or mechanic the amount of any costs reasonably anticipated in providing bona fide fringe benefits under a plan or program,

Provided, That the Secretary of Labor has found, upon the written request of the contractor, that the applicable standards of the Davis-Bacon Act have been met. The Secretary of Labor may require the contractor to set aside in a separate account, assets for the meeting of obligations under the plan or program.

(2) **Withholding.** The Contractor shall upon its own action or upon written request of an authorized representative of the Department of Labor withhold or cause to be withheld from the contractor under this contract or any other Federal contract with the same prime contractor, or any other federally-assisted contract subject to Davis-Bacon prevailing wage requirements, which is held by the same prime contractor, so much of the accrued payments or advances as may be considered necessary to pay laborers and mechanics, including apprentices, trainees, and helpers, employed by the contractor or any subcontractor the full amount of wages required by the contract. In the event of failure to pay any laborer or mechanic, including any apprentice, trainee, or helper, employed or working on the site of the work (or under the United States Housing Act of 1937 or under the Housing Act of 1949 in the construction or development of the project), all or part of the wages required by the contract, the (Agency) may, after written notice to the contractor, sponsor, applicant, or owner, take such action as may be necessary to cause the suspension of any further payment, advance, or guarantee of funds until such violations have ceased.

(3) **Payrolls and basic records.**

(i) Payrolls and basic records relating thereto shall be maintained by the contractor during the course of the work and preserved for a period of three years thereafter for all laborers and mechanics working at the site of the work (or under the United States Housing Act of 1937, or under the Housing Act of 1949, in the construction or development of the project). Such records shall contain the name, address, and social security number of each such worker, his or her correct classification, hourly rates of wages paid (including rates of contributions or costs anticipated for bona fide fringe benefits or cash equivalents thereof of the types described in section 1(b)(2)(B) of the Davis-Bacon Act), daily and weekly number of hours worked, deductions made and actual wages paid. Whenever the Secretary of Labor has found under [29 CFR 5.5\(a\)\(1\)\(iv\)](#) that the wages of any laborer or mechanic include the amount of any costs reasonably anticipated in providing benefits under a plan or program described in section 1(b)(2)(B) of the Davis-Bacon Act, the contractor shall maintain records which show that the commitment to provide such benefits is enforceable, that the plan or program is financially responsible, and that the plan or program has been communicated in writing to the laborers or mechanics affected, and records which show the costs anticipated or the actual cost incurred in providing such benefits. Contractors employing apprentices or trainees under

approved programs shall maintain written evidence of the registration of apprenticeship programs and certification of trainee programs, the registration of the apprentices and trainees, and the ratios and wage rates prescribed in the applicable programs.

(ii)

(A) The contractor shall submit weekly for each week in which any contract work is performed a copy of all payrolls to the (write in name of appropriate federal agency) if the agency is a party to the contract, but if the agency is not such a party, the contractor will submit the payrolls to the applicant, sponsor, or owner, as the case may be, for transmission to the (write in name of agency). The payrolls submitted shall set out accurately and completely all of the information required to be maintained under [29 CFR 5.5\(a\)\(3\)\(i\)](#), except that full social security numbers and home addresses shall not be included on weekly transmittals. Instead the payrolls shall only need to include an individually identifying number for each employee (e.g., the last four digits of the employee's social security number). The required weekly payroll information may be submitted in any form desired. Optional Form WH-347 is available for this purpose from the Wage and Hour Division Web site at <http://www.dol.gov/esa/whd/forms/wh347instr.htm> or its successor site. The prime contractor is responsible for the submission of copies of payrolls by all subcontractors. Contractors and subcontractors shall maintain the full social security number and current address of each covered worker, and shall provide them upon request to the (write in name of appropriate federal agency) if the agency is a party to the contract, but if the agency is not such a party, the contractor will submit them to the applicant, sponsor, or owner, as the case may be, for transmission to the (write in name of agency), the contractor, or the Wage and Hour Division of the Department of Labor for purposes of an investigation or audit of compliance with prevailing wage requirements. It is not a violation of this section for a prime contractor to require a subcontractor to provide addresses and social security numbers to the prime contractor for its own records, without weekly submission to the sponsoring government agency (or the applicant, sponsor, or owner).

(B) Each payroll submitted shall be accompanied by a "Statement of Compliance," signed by the contractor or subcontractor or his or her agent who pays or supervises the payment of the persons employed under the contract and shall certify the following:

(1) That the payroll for the payroll period contains the information required to be provided under § 5.5 (a)(3)(ii) of Regulations, [29 CFR part 5](#), the appropriate information is being maintained under § 5.5 (a)(3)(i) of

Regulations, [29 CFR part 5](#), and that such information is correct and complete;

(2) That each laborer or mechanic (including each helper, apprentice, and trainee) employed on the contract during the payroll period has been paid the full weekly wages earned, without rebate, either directly or indirectly, and that no deductions have been made either directly or indirectly from the full wages earned, other than permissible deductions as set forth in Regulations, [29 CFR part 3](#);

(3) That each laborer or mechanic has been paid not less than the applicable wage rates and fringe benefits or cash equivalents for the classification of work performed, as specified in the applicable wage determination incorporated into the contract.

(C) The weekly submission of a properly executed certification set forth on the reverse side of Optional Form WH-347 shall satisfy the requirement for submission of the “Statement of Compliance” required by [paragraph \(a\)\(3\)\(ii\)\(B\)](#) of this section.

(D) The falsification of any of the above certifications may subject the contractor or subcontractor to civil or criminal prosecution under section 1001 of title 18 and section 231 of title 31 of the United States Code.

(iii) The contractor or subcontractor shall make the records required under [paragraph \(a\)\(3\)\(i\)](#) of this section available for inspection, copying, or transcription by authorized representatives of the (write the name of the agency) or the Department of Labor, and shall permit such representatives to interview employees during working hours on the job. If the contractor or subcontractor fails to submit the required records or to make them available, the Federal agency may, after written notice to the contractor, sponsor, applicant, or owner, take such action as may be necessary to cause the suspension of any further payment, advance, or guarantee of funds. Furthermore, failure to submit the required records upon request or to make such records available may be grounds for debarment action pursuant to [29 CFR 5.12](#).

(4) Apprentices and trainees —

(i) **Apprentices.** Apprentices will be permitted to work at less than the predetermined rate for the work they performed when they are employed pursuant to and individually registered in a bona fide apprenticeship program registered with the U.S. Department of Labor, Employment and Training Administration, Office of Apprenticeship Training, Employer and Labor Services, or with a State Apprenticeship Agency recognized by the Office, or if a person is employed in his or her first 90 days of probationary

employment as an apprentice in such an apprenticeship program, who is not individually registered in the program, but who has been certified by the Office of Apprenticeship Training, Employer and Labor Services or a State Apprenticeship Agency (where appropriate) to be eligible for probationary employment as an apprentice. The allowable ratio of apprentices to journeymen on the job site in any craft classification shall not be greater than the ratio permitted to the contractor as to the entire work force under the registered program. Any worker listed on a payroll at an apprentice wage rate, who is not registered or otherwise employed as stated above, shall be paid not less than the applicable wage rate on the wage determination for the classification of work actually performed. In addition, any apprentice performing work on the job site in excess of the ratio permitted under the registered program shall be paid not less than the applicable wage rate on the wage determination for the work actually performed. Where a contractor is performing construction on a project in a locality other than that in which its program is registered, the ratios and wage rates (expressed in percentages of the journeyman's hourly rate) specified in the contractor's or subcontractor's registered program shall be observed. Every apprentice must be paid at not less than the rate specified in the registered program for the apprentice's level of progress, expressed as a percentage of the journeymen hourly rate specified in the applicable wage determination. Apprentices shall be paid fringe benefits in accordance with the provisions of the apprenticeship program. If the apprenticeship program does not specify fringe benefits, apprentices must be paid the full amount of fringe benefits listed on the wage determination for the applicable classification. If the Administrator determines that a different practice prevails for the applicable apprentice classification, fringes shall be paid in accordance with that determination. In the event the Office of Apprenticeship Training, Employer and Labor Services, or a State Apprenticeship Agency recognized by the Office, withdraws approval of an apprenticeship program, the contractor will no longer be permitted to utilize apprentices at less than the applicable predetermined rate for the work performed until an acceptable program is approved.

(ii) **Trainees.** Except as provided in [29 CFR 5.16](#), trainees will not be permitted to work at less than the predetermined rate for the work performed unless they are employed pursuant to and individually registered in a program which has received prior approval, evidenced by formal certification by the U.S. Department of Labor, Employment and Training Administration. The ratio of trainees to journeymen on the job site shall not be greater than permitted under the plan approved by the Employment and Training Administration. Every trainee must be paid at not less than the rate specified in the approved program for the trainee's level of progress, expressed as a percentage of the journeyman hourly rate specified in the applicable wage determination. Trainees shall be paid fringe benefits in accordance with the provisions of the trainee program. If the trainee

program does not mention fringe benefits, trainees shall be paid the full amount of fringe benefits listed on the wage determination unless the Administrator of the Wage and Hour Division determines that there is an apprenticeship program associated with the corresponding journeyman wage rate on the wage determination which provides for less than full fringe benefits for apprentices. Any employee listed on the payroll at a trainee rate who is not registered and participating in a training plan approved by the Employment and Training Administration shall be paid not less than the applicable wage rate on the wage determination for the classification of work actually performed. In addition, any trainee performing work on the job site in excess of the ratio permitted under the registered program shall be paid not less than the applicable wage rate on the wage determination for the work actually performed. In the event the Employment and Training Administration withdraws approval of a training program, the contractor will no longer be permitted to utilize trainees at less than the applicable predetermined rate for the work performed until an acceptable program is approved.

(iii) **Equal employment opportunity.** The utilization of apprentices, trainees and journeymen under this part shall be in conformity with the equal employment opportunity requirements of Executive Order 11246, as amended, and [29 CFR part 30](#).

(5) **Compliance with Copeland Act requirements.** The contractor shall comply with the requirements of [29 CFR part 3](#), which are incorporated by reference in this contract.

(6) **Subcontracts.** The contractor or subcontractor shall insert in any subcontracts the clauses contained in [29 CFR 5.5\(a\)\(1\)](#) through [\(10\)](#) and such other clauses as the (write in the name of the Federal agency) may by appropriate instructions require, and also a clause requiring the subcontractors to include these clauses in any lower tier subcontracts. The prime contractor shall be responsible for the compliance by any subcontractor or lower tier subcontractor with all the contract clauses in [29 CFR 5.5](#).

(7) **Contract termination: debarment.** A breach of the contract clauses in [29 CFR 5.5](#) may be grounds for termination of the contract, and for debarment as a contractor and a subcontractor as provided in [29 CFR 5.12](#).

(8) **Compliance with Davis-Bacon and Related Act requirements.** All rulings and interpretations of the Davis-Bacon and Related Acts contained in [29 CFR parts 1, 3, and 5](#) are herein incorporated by reference in this contract.

(9) **Disputes concerning labor standards.** Disputes arising out of the labor standards provisions of this contract shall not be subject to the general

disputes clause of this contract. Such disputes shall be resolved in accordance with the procedures of the Department of Labor set forth in [29 CFR parts 5, 6, and 7](#). Disputes within the meaning of this clause include disputes between the contractor (or any of its subcontractors) and the contracting agency, the U.S. Department of Labor, or the employees or their representatives.

(10) ***Certification of eligibility.***

(i) By entering into this contract, the contractor certifies that neither it (nor he or she) nor any person or firm who has an interest in the contractor's firm is a person or firm ineligible to be awarded Government contracts by virtue of section 3(a) of the Davis-Bacon Act or [29 CFR 5.12\(a\)\(1\)](#).

(ii) No part of this contract shall be subcontracted to any person or firm ineligible for award of a Government contract by virtue of section 3(a) of the Davis-Bacon Act or [29 CFR 5.12\(a\)\(1\)](#).

(iii) The penalty for making false statements is prescribed in the U.S. Criminal Code, [18 U.S.C. 1001](#).

E) CONTRACT WORK HOURS AND SAFETY STANDARDS ACT (40 U.S.C. 3701- 3708)

Where applicable, all contracts awarded in excess of \$100,000 that involve the employment of mechanics or laborers must be in compliance with 40 U.S.C. 3702 and 3704, as supplemented by Department of Labor regulations (29 CFR Part 5).

1. Overtime requirements. No Contractor or subcontractor contracting for any part of the contract work which may require or involve the employment of laborers or mechanics shall require or permit any such laborer or mechanic in any workweek in which he or she is employed on such work to work in excess of forty hours in such workweek unless such laborer or mechanic receives compensation at a rate not less than one and one-half times the basic rate of pay for all hours worked in excess of forty hours in such workweek.
2. Violation; liability for unpaid wages; liquidated damages. In the event of any violation of the clause set forth in paragraph (1) of this section the Contractor and any subcontractor responsible therefor shall be liable for the unpaid wages. In addition, such Contractor and subcontractor shall be liable to the United States (in the case of work done under contract for the District of Columbia or a territory, to such District or to such territory), for liquidated damages. Such liquidated damages shall be computed with respect to each individual laborer or mechanic, including watchmen and guards, employed in violation of the clause set forth in paragraph (1) of this section, in the sum of

\$10 for each calendar day on which such individual was required or permitted to work in excess of the standard workweek of forty hours without payment of the overtime wages required by the clause set forth in paragraph (1) of this section.

3. Withholding for unpaid wages and liquidated damages. The Owner shall upon its own action or upon written request of an authorized representative of the Department of Labor withhold or cause to be withheld, from any moneys payable on account of work performed by the Contractor or subcontractor under any such contract or any other Federal contract with the same prime Contractor, or any other federally-assisted contract subject to the Contract Work Hours and Safety Standards Act, which is held by the same prime Contractor, such sums as may be determined to be necessary to satisfy any liabilities of such Contractor or subcontractor for unpaid wages and liquidated damages as provided in the clause set forth in paragraph (2) of this section.
4. Subcontractors. The Contractor or subcontractor shall insert in any subcontracts the clauses set forth in paragraph (1) through (4) of this section and also a clause requiring the subcontracts to include these clauses in any lower tier subcontracts. The prime Contractor shall be responsible for compliance by any sub-contractors or lower tier subcontractor with the clauses set forth in paragraphs (1) through (4) of this section.”

F) RIGHT TO INVENTIONS MADE UNDER A CONTRACT OR AGREEMENT

If this award meetings the definition of a “funding agreement” under 37 C.F.R. § 401.2(a), the following standard patent rights are applicable:

Standard Patent Rights

(a) Definitions

- (1) *Invention*** means any invention or discovery which is or may be patentable or otherwise protectable under Title 35 of the United States Code, or any novel variety of plant which is or may be protected under the Plant Variety Protection Act (7 U.S.C. 2321 et seq.).
- (2) *Subject invention*** means any invention of the *contractor* conceived or first actually reduced to practice in the performance of work under this *contract*, provided that in the case of a variety of plant, the date of determination (as defined in section 41(d) of the Plant Variety Protection Act, 7 U.S.C. 2401(d)) must also occur during the period of *contract* performance.
- (3) *Practical Application*** means to manufacture in the case of a composition or product, to practice in the case of a process or method, or to operate in the case of a machine or system; and, in each case, under such conditions as to

establish that the [invention](#) is being utilized and that its benefits are, to the extent permitted by law or government regulations, available to the public on reasonable terms.

(4) *Made* when used in relation to any [invention](#) means the conception or first actual reduction to practice of such [invention](#).

(5) *Small Business Firm* means a small business concern as defined at section 2 of [Pub. L. 85-536 \(15 U.S.C. 632\)](#) and implementing regulations of the Administrator of the Small Business Administration. For the purpose of this clause, the size standards for small business concerns involved in government procurement and subcontracting at [13 CFR 121.3-8](#) and [13 CFR 121.3-12](#), respectively, will be used.

(6) *Nonprofit Organization* means a university or other institution of higher education or an organization of the type described in section 501(c)(3) of the [Internal Revenue Code of 1954 \(26 U.S.C. 501\(c\)\)](#) and exempt from taxation under section 501(a) of the [Internal Revenue Code \(25 U.S.C. 501\(a\)\)](#) or any nonprofit scientific or educational organization qualified under a state [nonprofit organization](#) statute.

(7) *Statutory period* means the one-year period before the effective filing date of a claimed [invention](#) in a [patent application](#) during which exceptions to prior art exist per [35 U.S.C. 102\(b\)](#) as amended by the [Leahy-Smith America Invents Act, Public Law 112-29](#).

(8) *Contractor* means any person, [small business firm](#), or [nonprofit organization](#), or, as set forth in section 1, paragraph (b)(4) of [Executive Order 12591](#), as amended, any business firm regardless of size, which is a party to a [funding agreement](#).

(b) Allocation of Principal Rights

The *Contractor* may retain the entire right, title, and interest throughout the world to each [subject invention](#) subject to the provisions of this clause and [35 U.S.C. 203](#). With respect to any [subject invention](#) in which the *Contractor* retains title, the Federal government shall have a nonexclusive, nontransferable, irrevocable, paid-up license to practice or have practiced for or on behalf of the United States the [subject invention](#) throughout the world.

(c) Invention Disclosure, Election of Title and Filing of Patent Application by Contractor

(1) The *contractor* will disclose each [subject invention](#) to the *Federal agency* within two months after the inventor discloses it in writing to *contractor* personnel responsible for patent matters. The disclosure to the agency shall be in the form of a written report and shall identify the *contract* under which the [invention](#) was [made](#) and the inventor(s). It shall be sufficiently complete in technical detail to convey a clear understanding to the extent known at the time of the disclosure, of the nature, purpose, operation, and the physical, chemical, biological or electrical characteristics of

the invention. The disclosure shall also identify any publication, on sale or public use of the invention, and whether a manuscript describing the invention has been submitted for publication and, if so, whether it has been accepted for publication at the time of disclosure. In addition, after disclosure to the *agency*, the *contractor* will promptly notify the *agency* of the acceptance of any manuscript describing the invention for publication or of any on sale or public use planned by the *contractor*. If required by the *Federal agency*, the *contractor* will provide periodic (but no more frequently than annual) listings of all subject inventions which were disclosed to the agency during the period covered by the report, and will provide a report prior to the close-out of a funding agreement listing all subject inventions or stating that there were none.

(2) The *contractor* will elect in writing whether or not to retain title to any such invention by notifying the *Federal agency* within two years of disclosure to the *Federal agency*. However, in any case where a patent, a printed publication, public use, sale, or other availability to the public has initiated the one year statutory period wherein valid patent protection can still be obtained in the United States, the period for election of title may be shortened by the *agency* to a date that is no more than 60 days prior to the end of the statutory period.

(3)

(i) The *contractor* will file its initial patent application on a subject invention to which it elects to retain title within one year after election of title or, if earlier, prior to the end of any statutory period wherein valid patent protection can be obtained in the United States after a publication, on sale, or public use.

(ii) If the *contractor* files a provisional application as its initial patent application, it shall file a nonprovisional application within 10 months of the filing of the provisional application. So long as there is a pending patent application for the subject invention and the statutory period wherein valid patent protection can be obtained in the United States has not expired, additional provisional applications may be filed within the initial 10 months or any extension period granted under paragraph (c)(5) of this clause. If an extension(s) is granted under paragraph (c)(5) of this clause, the *contractor* shall file a nonprovisional patent application prior to the expiration of the extension(s) or notify the agency of any decision not to file a nonprovisional application prior to the expiration of the extension(s), or if earlier, 60 days prior to the end of any statutory period wherein valid patent protection can be obtained in the United States.

(iii) The *contractor* will file patent applications in additional countries or international patent offices within either ten months of the first filed patent application or six months from the date permission is granted by the

Commissioner of Patents to file foreign [patent applications](#) where such filing has been prohibited by a Secrecy Order.

(iv) If required by the **Federal agency**, the *contractor* will provide the filing date, [patent application](#) number and title; a copy of the [patent application](#); and patent number and issue date for any [subject invention](#) in any country in which the *contractor* has applied for a patent.

(4) For any [subject invention](#) with *Federal agency* and *contractor* co-inventors, where the *Federal agency* employing such co-inventor determines that it would be in the interest of the government, pursuant to [35 U.S.C. 207\(a\)\(3\)](#), to file an [initial patent application](#) on the [subject invention](#), the *Federal agency* employing such co-inventor, at its discretion and in consultation with the *contractor*, may file such application at its own expense, provided that the *contractor* retains the ability to elect title pursuant to [35 U.S.C. 202\(a\)](#).

(5) Requests for extension of the time for disclosure, election, and filing under paragraphs (1), (2), and (3) of this clause may, at the discretion of the **Federal agency**, be granted. When a *contractor* has requested an extension for filing a non-provisional application after filing a provisional application, a one-year extension will be granted unless the *Federal agency* notifies the *contractor* within 60 days of receiving the request.

(6) In the event a [subject invention](#) is [made](#) under funding agreements of more than one agency, at the request of the *contractor* or on their own initiative the agencies shall designate one agency as responsible for administration of the rights of the government in the [invention](#).

(d) Conditions When the Government May Obtain Title

(1) A **Federal agency** may require the *contractor* to convey title to the *Federal agency* of any subject invention—

(i) If the **contractor** fails to disclose or elect title to the [subject invention](#) within the times specified in paragraph (c) of this clause, or elects not to retain title.

(ii) In those countries in which the **contractor** fails to file [patent applications](#) within the times specified in paragraph (c) of this clause; provided, however, that if the *contractor* has filed a [patent application](#) in a country after the times specified in paragraph (c) of this clause, but prior to its receipt of the written request of the *Federal agency*, the *contractor* shall continue to retain title in that country.

(iii) In any country in which the **contractor** decides not to continue the prosecution of any nonprovisional [patent application](#) for, to pay a maintenance, annuity or renewal fee on, or to defend in a reexamination or opposition proceeding on, a patent on a [subject invention](#).

(2) A **Federal agency**, at its discretion, may waive the requirement for the *contractor* to convey title to any [subject invention](#).

(e) Minimum Rights to Contractor and Protection of the Contractor Right to File

(1) The **contractor** will retain a nonexclusive royalty-free license throughout the world in each [subject invention](#) to which the Government obtains title, except if the *contractor* fails to disclose the [invention](#) within the times specified in (c), above. The *contractor's* license extends to its domestic subsidiary and affiliates, if any, within the corporate structure of which the *contractor* is a party and includes the right to grant sublicenses of the same scope to the extent the *contractor* was legally obligated to do so at the time the *contract* was awarded. The license is transferable only with the approval of the *Federal agency* except when transferred to the successor of that party of the *contractor's* business to which the [invention](#) pertains.

(2) The **contractor's** domestic license may be revoked or modified by the *funding Federal agency* to the extent necessary to achieve expeditious [practical application](#) of the [subject invention](#) pursuant to an application for an exclusive license submitted in accordance with applicable provisions at [37 CFR part 404](#) and *agency* licensing regulations (if any). This license will not be revoked in that field of use or the geographical areas in which the *contractor* has achieved [practical application](#) and continues to make the benefits of the [invention](#) reasonably accessible to the public. The license in any foreign country may be revoked or modified at the discretion of the *funding Federal agency* to the extent the *contractor*, its licensees, or the domestic subsidiaries or affiliates have failed to achieve [practical application](#) in that foreign country.

(3) Before revocation or modification of the license, the **funding Federal agency** will furnish the *contractor* a written notice of its intention to revoke or modify the license, and the *contractor* will be allowed thirty days (or such other time as may be authorized by the *funding Federal agency* for good cause shown by the *contractor*) after the notice to show cause why the license should not be revoked or modified. The *contractor* has the right to appeal, in accordance with applicable regulations in [37 CFR part 404](#) and *agency* regulations (if any) concerning the licensing of Government-owned inventions, any decision concerning the revocation or modification of the license.

(f) Contractor Action to Protect the Government's Interest

(1) The **contractor** agrees to execute or to have executed and promptly deliver to the *Federal agency* all instruments necessary to (i) establish or confirm the rights the Government has throughout the world in those [subject inventions](#) to which the *contractor* elects to retain title, and (ii) convey title to the *Federal agency* when requested under paragraph (d) above and to enable the government to obtain patent protection throughout the world in that [subject invention](#).

(2) The **contractor** agrees to require, by written agreement, its employees, other than clerical and nontechnical employees, to disclose promptly in writing to personnel identified as responsible for the administration of patent matters and in a format suggested by the *contractor* each subject invention made under contract in order that the *contractor* can comply with the disclosure provisions of paragraph (c) of this clause, to assign to the *contractor* the entire right, title and interest in and to each subject invention made under contract, and to execute all papers necessary to file patent applications on subject inventions and to establish the government's rights in the subject inventions. This disclosure format should require, as a minimum, the information required by paragraph (c)(1) of this clause. The *contractor* shall instruct such employees through employee agreements or other suitable educational programs on the importance of reporting inventions in sufficient time to permit the filing of patent applications prior to U.S. or foreign statutory bars.

(3) For each subject invention, the *contractor* will, no less than 60 days prior to the expiration of the statutory deadline, notify the *Federal agency* of any decision: Not to continue the prosecution of a non-provisional patent application; not to pay a maintenance, annuity or renewal fee; not to defend in a reexamination or opposition proceeding on a patent, in any country; to request, be a party to, or take action in a trial proceeding before the Patent Trial and Appeals Board of the U.S. Patent and Trademark Office, including but not limited to post-grant review, review of a business method patent, *inter partes* review, and derivation proceeding; or to request, be a party to, or take action in a non-trial submission of art or information at the U.S. Patent and Trademark Office, including but not limited to a pre-issuance submission, a post-issuance submission, and supplemental examination.

(4) The **contractor** agrees to include, within the specification of any United States patent applications and any patent issuing thereon covering a subject invention, the following statement, "This invention was made with government support under (identify the *contract*) awarded by (identify the Federal agency). The government has certain rights in the invention."

(g) Subcontracts

(1) The **contractor** will include this clause, suitably modified to identify the parties, in all subcontracts, regardless of tier, for experimental, developmental or research work to be performed by a subcontractor.. The subcontractor will retain all rights provided for the *contractor* in this clause, and the *contractor* will not, as part of the consideration for awarding the subcontract, obtain rights in the subcontractor's subject inventions.

(2) The **contractor** will include in all other subcontracts, regardless of tier, for experimental developmental or research work the patent rights clause required by (cite section of agency implementing regulations or FAR).

(3) In the case of subcontracts, at any tier, when the prime award with the Federal agency was a contract (but not a grant or cooperative agreement), the **agency**, subcontractor, and the contractor agree that the mutual obligations of the parties created by this clause constitute a contract between the subcontractor and the Federal agency with respect to the matters covered by the clause; provided, however, that nothing in this paragraph is intended to confer any jurisdiction under the Contract Disputes Act in connection with proceedings under paragraph (j) of this clause.

(h) Reporting on Utilization of Subject Inventions

The *Contractor* agrees to submit on request periodic reports no more frequently than annually on the utilization of a subject invention or on efforts at obtaining such utilization that are being made by the *contractor* or its licensees or assignees. Such reports shall include information regarding the status of development, date of first commercial sale or use, gross royalties received by the contractor, and such other data and information as the *agency* may reasonably specify. The *contractor* also agrees to provide additional reports as may be requested by the *agency* in connection with any march-in proceeding undertaken by the *agency* in accordance with paragraph (j) of this clause. As required by 35 U.S.C. 202(c)(5), the *agency* agrees it will not disclose such information to persons outside the government without permission of the *contractor*.

(i) Preference for United States Industry

Notwithstanding any other provision of this clause, the *contractor* agrees that neither it nor any assignee will grant to any person the exclusive right to use or sell any subject inventions in the United States unless such person agrees that any products embodying the subject invention or produced through the use of the subject invention will be manufactured substantially in the United States. However, in individual cases, the requirement for such an agreement may be waived by the *Federal agency* upon a showing by the *contractor* or its assignee that reasonable but unsuccessful efforts have been made to grant licenses on similar terms to potential licensees that would be likely to manufacture substantially in the United States or that under the circumstances domestic manufacture is not commercially feasible.

(j) March-in Rights

The *contractor* agrees that with respect to any subject invention in which it has acquired title, the *Federal agency* has the right in accordance with the procedures in 37 CFR 401.6 and any supplemental regulations of the *agency* to require the *contractor*, an assignee or exclusive licensee of a subject invention to grant a nonexclusive, partially exclusive, or exclusive license in any field of use to a responsible applicant or applicants, upon terms that are reasonable under

the circumstances, and if the *contractor*, assignee, or exclusive licensee refuses such a request the *Federal agency* has the right to grant such a license itself if the *Federal agency* determines that:

- (1) Such action is necessary because the ***contractor*** or assignee has not taken, or is not expected to take within a reasonable time, effective steps to achieve practical application of the subject invention in such field of use.
- (2) Such action is necessary to alleviate health or safety needs which are not reasonably satisfied by the ***contractor***, assignee or their licensees;
- (3) Such action is necessary to meet requirements for public use specified by Federal regulations and such requirements are not reasonably satisfied by the ***contractor***, assignee or licensees; or
- (4) Such action is necessary because the agreement required by paragraph (i) of this clause has not been obtained or waived or because a licensee of the exclusive right to use or sell any subject invention in the United States is in breach of such agreement.

(k) Special Provisions for Contracts with Nonprofit Organizations

If the *contractor* is a nonprofit organization, it agrees that:

- (1) Rights to a subject invention in the United States may not be assigned without the approval of the *Federal agency*, except where such assignment is made to an organization which has as one of its primary functions the management of inventions, provided that such assignee will be subject to the same provisions as the *contractor*;
- (2) The ***contractor*** will share royalties collected on a subject invention with the inventor, including Federal employee co-inventors (when the agency deems it appropriate) when the subject invention is assigned in accordance with 35 U.S.C. 202(e) and 37 CFR 401.10;
- (3) The balance of any royalties or income earned by the ***contractor*** with respect to subject inventions, after payment of expenses (including payments to inventors) incidental to the administration of subject inventions, will be utilized for the support of scientific research or education; and
- (4) It will make efforts that are reasonable under the circumstances to attract licensees of subject inventions that are small business firms and that, when appropriate, it will give a preference to a small business firm when licensing a subject invention;
- (5) The ***Federal agency*** may review the *contractor's* licensing program and decisions regarding small business applicants, and the *contractor* will negotiate changes to its licensing policies, procedures, or practices with the *Federal agency* when the *Federal agency's* review discloses that the *contractor* could take reasonable steps to more effectively implement the requirements of paragraph (k)(4) of this clause; and

(6) The **Federal agency** may take into consideration concerns presented by small businesses in making such determinations in paragraph (k)(5) of this clause.

(l) Communication

[Complete according to instructions at [§ 401.5\(b\)](#)]

(m) Electronic Filing

(1) Unless otherwise requested or directed by the **Federal agency**—

(i) The written disclosure required in (c)(1) of this clause shall be [electronically filed](#);

(ii) The written election required in (c)(2) of this clause shall be [electronically filed](#); and

(iii) If required by the agency to be submitted, the close-out report in paragraph (c)(1) of this clause and the patent information and periodic reporting identified in paragraph (c)(3) of this clause shall be [electronically filed](#).

(2) Other written notices required in this clause may be electronically delivered to the agency or the **contractor** through an electronic database used for reporting subject inventions, patents, and utilization reports to the funding agency.

G) CLEAN AIR ACT (42 U.S.C. 7401-7671q AND THE FEDERAL WATER POLLUTION CONTROL ACT (33 U.S.C. 1251-1387), AS AMENDED.

The Contractor agrees to comply with all applicable standards, orders or regulations issued pursuant to the Clean Air Act, as amended, 42 U.S.C. § 7401, et. seq. The Contractor agrees to report each violation to the Board and understands and agrees that the Board will, in turn, report each violation as required to assure notification to the Federal Emergency Management Agency, and the appropriate Environmental Protection Agency Regional Office. The contractor agrees to include these requirements in each subcontract exceeding \$150,000 financed in whole or in part with Federal Assistance.

The Contractor agrees to comply with all applicable standards, orders or regulations issued pursuant to the Federal Water Pollution Control Act, as amended, 33 U.S.C. § 1251, et. seq. The Contractor agrees to report each violation to the Board and understands and agrees that the Board will, in turn, report each violation as required to assure notification to the Federal Emergency Management Agency, and the appropriate Environmental Protection Agency Regional Office. The contractor agrees to include these

requirements in each subcontract exceeding \$150,000 financed in whole or in part with Federal Assistance.

H) DEBARMENT AND SUSPENSION (EXECUTIVE ORDERS 12549 and 12689)

- (1) This contract is a covered transaction for purposes of 2 C.F.R. pt. 180 and 2 C.F.R. pt. 3000. As such, the contractor is required to verify that none of the contractor's principals (defined at 2 C.F.R. § 180.995) or its affiliates (defined at 2 C.F.R. § 180.905) are excluded (defined at 2 C.F.R. § 180.940) or disqualified (defined at 2 C.F.R. § 180.935).
- (2) The Contractor must comply with 2 C.F.R. pt. 180, subpart C and 2 C.F.R., pt. 3000, subpart C, and must include a requirement to comply with these regulations in any lower tier covered transaction it enter into.
- (3) This certification is a material representation of fact relied upon by the Board. If it is later determined that the Contractor did not comply with 2 C.F.R. pt. 180, subpart C and 2 C.F.R. pt. 3000, subpart C, in addition to remedies available to the Board, the Federal Government may pursue available remedies, including but not limited to suspension and/or debarment.

I) BYRD ANTI-LOBBYING AMENDMENT (31 U.S.C. 1352)

Contractors who apply or bid for an award of \$100,000 or more shall file the required certification. Each tier certifies to the tier above that it will not and has not used Federal appropriated funds to pay any person or organization for influencing or attempting to influence an officer or employee of any agency, a member of Congress, officer or employee of Congress, or an employee of a member of Congress in connection with obtaining any Federal contract, grant, or any other award covered by 31 U.S.C. § 1352. Each tier shall also disclose any lobbying with non-Federal funds that takes place in connection with obtaining any Federal award. Such disclosures are forwarded from tier to tier up to the recipient who in turn will forward the certification(s) to the awarding agency. A copy of the required certification is attached hereto as Appendix A.

J) PROCUREMENT OF RECOVERED MATERIALS

In the performance of this contract, the Contractor shall make maximum use of products containing recovered materials that are EPA-designated items unless the product cannot be acquired:

1. Competitively within a timeframe providing for compliance with the contract performance schedule;
2. Meeting contract performance requirements; or
3. At a reasonable price.

Information about this requirement, along with the list of EPA-designated items, is available at EPA's Comprehensive Procurement Guidelines website, <https://www.epa.gov/smm/comprehensive-procurement-guideline-cpg-program>

The Contractor also agrees to comply with all other applicable requirements of Section 6002 of the Solid Waste Disposal Act.

K) PROHIBITION ON CERTAIN TELECOMMUNICATIONS AND VIDEO SURVEILLANCE SERVICES OR EQUIPMENT

Recipients of federal funds are prohibited from obligating or expending loan or grant funds to:

- (1) Procure or obtain;
- (2) Extend or renew a contract to procure or obtain; or
- (3) Enter into a contract (or extend or renew a contract) to procure or obtain equipment, services, or systems that uses covered telecommunications equipment or services as a substantial or essential component of any system, or as critical technology as part of any system. As described in Public Law 115-232, section 889, covered telecommunications equipment is telecommunications equipment produced by Huawei Technologies Company or ZTE Corporation (or any subsidiary or affiliate of such entities).
 - (i) For the purpose of public safety, security of government facilities, physical security surveillance of critical infrastructure, and other national security purposes, video surveillance and telecommunications equipment produced by Hytera Communications Corporation, Hangzhou Hikvision Digital Technology Company or Dahua Technology Company (or subsidiary or affiliate of such entities).
 - (ii) Telecommunications or video surveillance services provided by such entities or using such equipment.
 - (iii) Telecommunications or video surveillance equipment or services produced or provided by an entity that the Secretary of Defense, in consultation with the Director of the National

Intelligence or the Director of the Federal Bureau of Investigation, reasonably believes to be an entity owned or controlled by, or otherwise connected to, the government of a covered foreign county.

L) DOMESTIC PREFERENCES FOR PROCUREMENTS (BUY AMERICAN)

In the performance of this contract and to the extent permitted by law, the Contractor shall maximize the use of goods, products, and materials produced in the United States unless the goods, products or materials cannot be acquired:

1. Competitively within a timeframe providing for compliance with the contract performance schedule;
2. Meeting contract performance requirements; or
3. At a reasonable price.

M) COPELAND “ANTI-KICKBACK” ACT

For all construction contracts greater than \$2,000, Contractor must comply with the requirements of the Copeland “Anti-Kickback” Act (18 U.S.C. § 874 and 40 U.S.C. § 3145) and the requirements of 29 CFR Part 3 *as may be applicable*, which are incorporated by reference into this contract.

Contractor and subcontractors are prohibited from inducing, by any means, any person employed on the project to give up any part of the compensation to which the employee is entitled. The Contractor and each subcontractor must submit to the Owner, a weekly statement on the wages paid to each employee performing on covered work during the prior week.

Subcontracts. The Contractor or subcontractor shall insert in any subcontracts the clause above and such other clauses as FEMA may by appropriate instructions require, and also a clause requiring the subcontractors to include these clauses in any lower tier subcontracts. The prime Contractor shall be responsible for the compliance by any subcontractor or lower tier subcontractor with all of these contract clauses.

Breach. A breach of the contract clauses above may be grounds for termination of the contract, and for debarment as a Contractor and subcontractor as provided in 29 CFR § 5.12.”

Disputes Concerning Labor. Disputes arising out of the labor standards provisions of this contract shall not be subject to the general disputes clause of this contract. Such disputes shall be resolved in accordance with the procedures of the Department of Labor set forth in 29 CFR Parts 5, 6, and 7. Disputes within

the meaning of this clause include disputes between the Contractor (or any of its subcontractors) and the contracting agency, the U.S. Department of Labor, or the employees or their representatives.

N) DRUG FREE WORKPLACE REQUIREMENTS

Drug-free workplace requirements in accordance with the Drug Free Workplace Act of 1988 (Pub 100-690, Title V, Subtitle D) requires that all contractors entering into federally funded contracts over \$100,000 must comply with Federal Drug Free workplace requirements.

[REMAINDER OF THIS PAGE INTENTIONALLY LEFT BLANK]

IN WITNESS THEREOF, the parties to this ADDENDUM through their duly authorized representatives have executed this ADDENDUM on the dates set out below, and certify that they have read, understood, and agreed to the terms and conditions of this ADDENDUM as set forth herein. All other terms and agreements of the Agreement remain in full force and effect.

Signature of Contractor's Authorized Official

Name and Title of Contractor's Authorized Official

Date

APPENDIX A, 44 C.F.R. PART 18 – CERTIFICATION REGARDING LOBBYING

Certification for Contracts, Grants, Loans and Cooperative Agreements

The undersigned certifies, to the best of his or her knowledge and belief, that:

1. No Federal appropriated funds have been paid or will be paid, by or on behalf of the undersigned, to any person for influencing or attempting to influence an officer or employee of any agency, a member of Congress, officer or employee of Congress, or an employee of a member of Congress in connection with the awarding of any Federal contract, the making of any Federal grant, the making of any Federal loan, the entering into of any cooperative agreement, and the extension, continuation, renewal, amendment, or modification of any Federal contract, grant, loan or cooperative agreement.
2. If any funds other than Federal appropriated funds have been paid or will be paid to any person for influencing or attempting to influence an officer or employee of any agency, a member of Congress, officer or employee of Congress, or an employee of a member of Congress in connection with this Federal contract, grant, loan or cooperative agreement, the undersigned shall complete and submit Standard Form -LLL, “disclosure Form to Report Lobbying,” in accordance with its instructions.
3. The undersigned shall require that the language of this certification be included in the award documents for all subawards at all tiers (including subcontracts, subgrants, and contracts under grants, loans, and cooperative agreements) and that all subrecipients shall certify and disclose accordingly.

This certification is a material representation of fact upon which reliance was placed when this transaction was made or entered into. Submission of this certification is a prerequisite for making or entering into this transaction imposed by section 1352, title 31, U.S. Code. Any person who fails to file the required certification shall be subject to a civil penalty of not less than \$10,000 and not more than \$100,000 for each such failure.

The Contractor, _____, certifies or affirms the truthfulness and accuracy of each statement of its certification and disclosure, if any. In addition, the Contractor understands and agrees that the provisions of 31 U.S.C. Ch. 38, Administrative Remedies for False Claims and Statements, apply to this certification and disclosure, if any.

Signature of Contractor's Authorized Official

Name and Title of Contractor's Authorized Official

Date

**ATTACHMENT NO. 12
DAVIS BACON WAGES**

"General Decision Number: FL20240140 01/05/2024

Superseded General Decision Number: FL20230140

State: Florida

Construction Type: Highway

County: Columbia County in Florida.

HIGHWAY CONSTRUCTION PROJECTS

Note: Contracts subject to the Davis-Bacon Act are generally required to pay at least the applicable minimum wage rate required under Executive Order 14026 or Executive Order 13658. Please note that these Executive Orders apply to covered contracts entered into by the federal government that are subject to the Davis-Bacon Act itself, but do not apply to contracts subject only to the Davis-Bacon Related Acts, including those set forth at 29 CFR 5.1(a)(2)-(60).

<ul style="list-style-type: none"> • If the contract is entered into on or after January 30, 2022, or the contract is renewed or extended (e.g., and option is exercised) on or after January 30, 2022: 	<ul style="list-style-type: none"> • Executive Order 14026 generally applies to the contract. • The contractor must pay all covered workers at least \$17.20 per hour (or the applicable wage rate listed on this wage determination, if it is higher) for all hours spent performing on the contract in 2024.
<ul style="list-style-type: none"> • If the contract was awarded on or between January 1, 2015 and January 29, 2022, and the contract is not renewed or extended on or after January 30, 2022: 	<ul style="list-style-type: none"> • Executive Order 13658 generally applies to the contract. • The contractor must pay all covered workers at least \$12.90 per hour (or the applicable wage rate listed on this wage determination, if it is higher) for all hours spent performing on the contract in 2024.

The applicable Executive Order minimum wage rate will be adjusted annually. If this contract is covered by one of the Executive Orders and a classification considered necessary for performance of work on the contract does not appear on this wage determination, the contractor must still submit a conformance request.

Additional information on contractor requirements and worker protections under the Executive Orders is available at <http://www.dol.gov/whd/govcontracts>

Modification Number Publication Date
0 01/05/2024

*** ELEC0349-002 09/01/2023**

	Rates	Fringes
ELECTRICIAN.....	\$ 39.81	14.62

SUFL2013-001 08/19/2013

	Rates	Fringes
CARPENTER, Includes Form Work	\$12.63**	0.00
CEMENT MASON/ CONCRETE FINISHER	\$ 13.19 **	0.00
FENCE ERECTOR	\$ 11.32 **	0.00
HIGHWAY/PARKING LOT STRIPING: Operator (Striping Machine)	\$ 12.63 **	0.00
HIGHWAY/PARKING LOT STRIPING: Operator (Spray Nozzleman)	\$ 10.02 **	0.00
INSTALLER – GUARDRAIL	\$ 14.74 **	0.00
IRONWORKER, REINFORCING	\$ 13.67 **	0.00
LABORER (Traffic Control Specialist)	\$ 9.75 **	0.00

LABORER: Asphalt, Includes Raker, Shoveler, Spreader and Distributor	\$ 10.23 **	0.00
LABORER: Common or General	\$ 9.06 **	0.00
LABORER: Flagger	\$ 9.41 **	0.00
LABORER: Grade Checker	\$ 10.97 **	0.00
LABORER: Landscape & Irrigation	\$ 8.35 **	0.00
LABORER: Pipelayer	\$ 13.34 **	0.00
OPERATOR: Backhoe/Excavator/ Trackhoe	\$ 12.21 **	0.00
OPERATOR: Bobcat/Skid Steer/Skid Loader	\$ 11.61 **	0.00
OPERATOR: Broom/ Sweeper	\$ 10.89 **	0.00
OPERATOR: Bulldozer	\$ 14.26 **	0.00
OPERATOR: Crane	\$ 17.83	0.00
OPERATOR: Forklift	\$ 10.75 **	0.00
OPERATOR: Grader/Blade	\$ 13.17 **	0.00
OPERATOR: Loader	\$ 11.86 **	0.00
OPERATOR: Mechanic	\$ 12.37 **	0.00
OPERATOR: Milling Machine	\$ 13.57 **	0.00
OPERATOR: Oiler	\$ 11.38 **	0.00
OPERATOR: Paver (Asphalt, Aggregate, and Concrete)	\$ 13.65 **	0.00
OPERATOR: Post Driver (Guardrail/Fences)	\$ 16.00 **	0.00

OPERATOR: Roller	\$ 10.11 **	0.00
OPERATOR: Screed	\$ 13.73 **	0.00
OPERATOR: Tractor	\$ 9.73 **	0.00
OPERATOR: Trencher	\$ 16.00 **	0.00
SIGN ERECTOR	\$ 13.15 **	0.00
TRAFFIC SIGNALIZATION: Mechanic and Electrician	\$ 17.44	0.00
TRUCK DRIVER: Lowboy Truck	\$ 15.24 **	0.00
TRUCK DRIVER: Water Truck	\$ 12.04 **	0.00
TRUCK DRIVER: Dump (All Axles)	\$ 10.71 **	0.00

WELDERS - Receive rate prescribed for craft performing operation to which welding is incidental.

=====

**** Workers in this classification may be entitled to a higher minimum wage under Executive Order 14026 (\$17.20) or 13658 (\$12.90). Please see the Note at the top of the wage determination for more information. Please also note that the minimum wage requirements of Executive Order 14026 are not currently being enforced as to any contract or subcontract to which the states of Texas, Louisiana, or Mississippi, including their agencies, are a party.**

Note: Executive Order (EO) 13706, Establishing Paid Sick Leave for Federal Contractors applies to all contracts subject to the Davis-Bacon Act for which the contract is awarded (and any solicitation was issued) on or after January 1, 2017. If this contract is covered by the EO, the contractor must provide employees with 1 hour of paid sick leave for every 30 hours they work, up to 56 hours of paid sick leave each year. Employees must be permitted to use paid sick leave for their own illness, injury or other health-related needs, including preventive care; to assist a family member (or person who is like family to the employee) who is ill, injured, or has other

health-related needs, including preventive care; or for reasons resulting from, or to assist a family member (or person who is like family to the employee) who is a victim of, domestic violence, sexual assault, or stalking. Additional information on contractor requirements and worker protections under the EO is available at <https://www.dol.gov/agencies/whd/government-contracts>.

Unlisted classifications needed for work not included within the scope of the classifications listed may be added after award only as provided in the labor standards contract clauses (29CFR 5.5 (a) (1) (iii)).

The body of each wage determination lists the classification and wage rates that have been found to be prevailing for the cited type(s) of construction in the area covered by the wage determination. The classifications are listed in alphabetical order of ""identifiers"" that indicate whether the particular rate is a union rate (current union negotiated rate for local), a survey rate (weighted average rate) or a union average rate (weighted union average rate).

Union Rate Identifiers

A four-letter classification abbreviation identifier enclosed in dotted lines beginning with characters other than ""SU"" or ""UAVG"" denotes that the union classification and rate were prevailing for that classification in the survey. Example: PLUM0198-005 07/01/2014. PLUM is an abbreviation identifier of the union which prevailed in the survey for this classification, which in this example would be Plumbers. 0198 indicates the local union number or district council number where applicable, i.e., Plumbers Local 0198. The next number, 005 in the example, is an internal number used in processing the wage determination. 07/01/2014 is the effective date of the most current negotiated rate, which in this example is July 1, 2014.

Union prevailing wage rates are updated to reflect all rate changes in the collective bargaining agreement (CBA) governing this classification and rate.

Survey Rate Identifiers

Classifications listed under the ""SU"" identifier indicate that no one rate prevailed for this classification in the survey and the published rate is derived by computing a weighted average

rate based on all the rates reported in the survey for that classification. As this weighted average rate includes all rates reported in the survey, it may include both union and non-union rates. Example: SULA2012-007 5/13/2014. SU indicates the rates are survey rates based on a weighted average calculation of rates and are not majority rates. LA indicates the State of Louisiana. 2012 is the year of survey on which these classifications and rates are based. The next number, 007 in the example, is an internal number used in producing the wage determination. 5/13/2014 indicates the survey completion date for the classifications and rates under that identifier.

Survey wage rates are not updated and remain in effect until a new survey is conducted.

Union Average Rate Identifiers

Classification(s) listed under the UAVG identifier indicate that no single majority rate prevailed for those classifications; however, 100% of the data reported for the classifications was union data. EXAMPLE: UAVG-OH-0010 08/29/2014. UAVG indicates that the rate is a weighted union average rate. OH indicates the state. The next number, 0010 in the example, is an internal number used in producing the wage determination. 08/29/2014 indicates the survey completion date for the classifications and rates under that identifier.

A UAVG rate will be updated once a year, usually in January of each year, to reflect a weighted average of the current negotiated/CBA rate of the union locals from which the rate is based.

WAGE DETERMINATION APPEALS PROCESS

1.) Has there been an initial decision in the matter? This can be:

- * an existing published wage determination
- * a survey underlying a wage determination
- * a Wage and Hour Division letter setting forth a position on a wage determination matter
- * a conformance (additional classification and rate) ruling

On survey related matters, initial contact, including requests for summaries of surveys, should be with the Wage and Hour National Office because National Office has responsibility for the Davis-Bacon survey program. If the response from this initial contact is not satisfactory, then the process described

in 2.) and 3.) should be followed.

With regard to any other matter not yet ripe for the formal process described here, initial contact should be with the Branch of Construction Wage Determinations. Write to:

Branch of Construction Wage Determinations
Wage and Hour Division
U.S. Department of Labor
200 Constitution Avenue, N.W.
Washington, DC 20210

2.) If the answer to the question in 1.) is yes, then an interested party (those affected by the action) can request review and reconsideration from the Wage and Hour Administrator (See 29 CFR Part 1.8 and 29 CFR Part 7). Write to:

Wage and Hour Administrator
U.S. Department of Labor
200 Constitution Avenue, N.W.
Washington, DC 20210

The request should be accompanied by a full statement of the interested party's position and by any information (wage payment data, project description, area practice material, etc.) that the requestor considers relevant to the issue.

3.) If the decision of the Administrator is not favorable, an interested party may appeal directly to the Administrative Review Board (formerly the Wage Appeals Board). Write to:

Administrative Review Board
U.S. Department of Labor
200 Constitution Avenue, N.W.
Washington, DC 20210

4.) All decisions by the Administrative Review Board are final.

=====

END OF GENERAL DECISION"

FGC DRAINAGE IMPROVEMENTS

132 SE FOUNDATION PLACE COLUMBIA COUNTY, FLORIDA

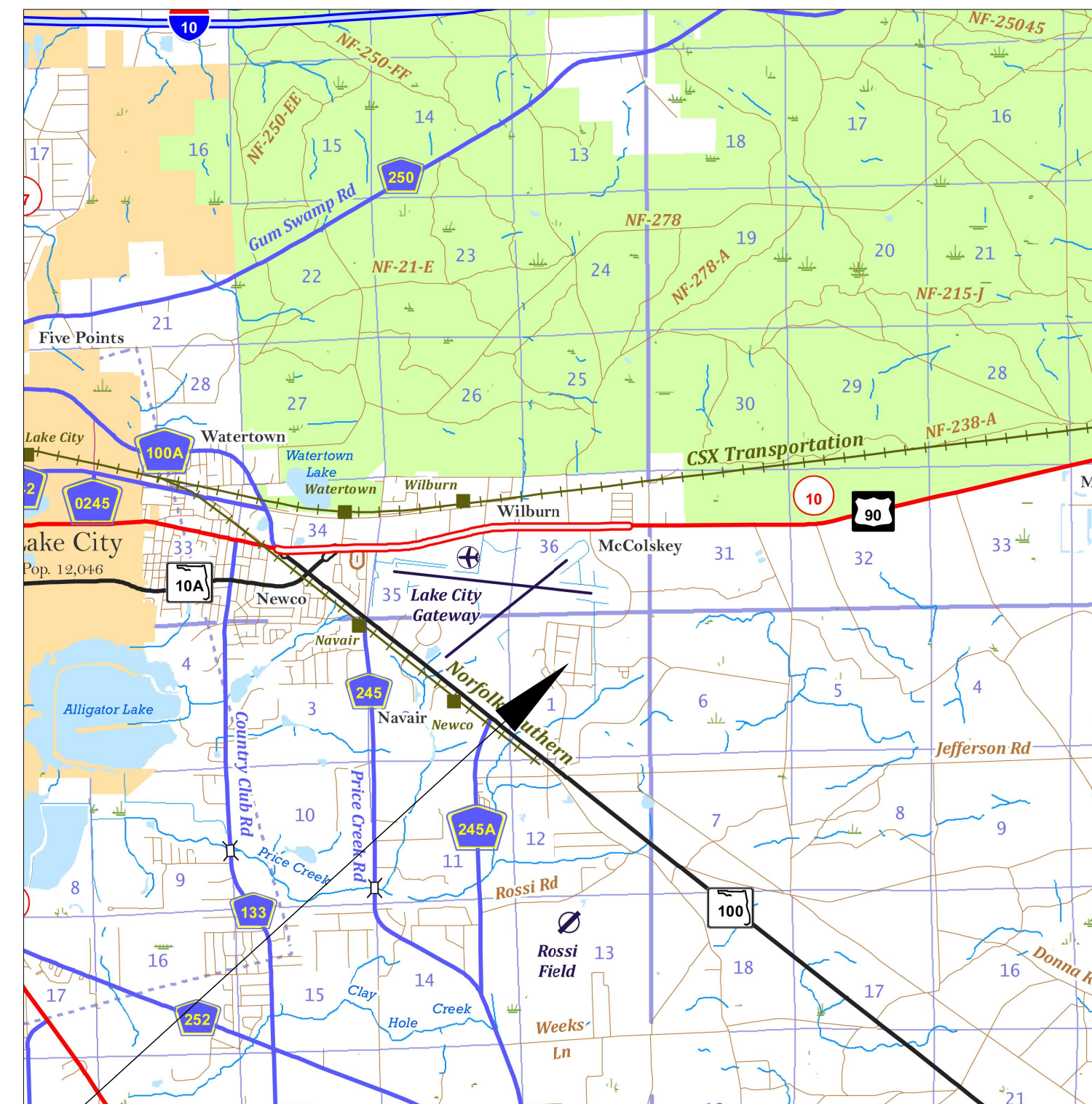
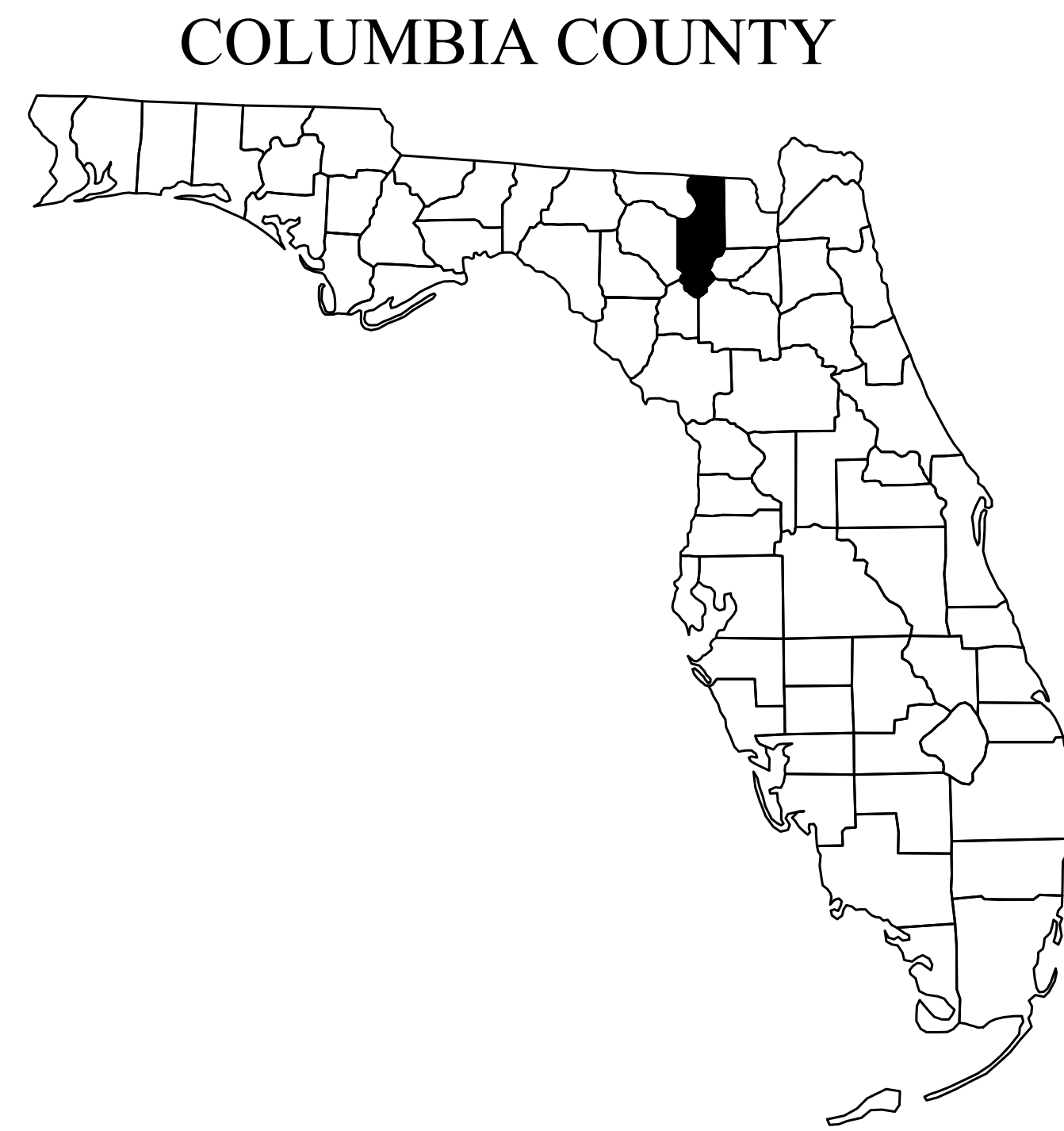

PROJECT LOCATION

REVISIONS

#	REVISION DESCRIPTION	DATE

SHEET INDEX

KEY SHEET	1
NOTES	2
OVERALL SITE PLAN	3
EXISTING CONDITIONS A	4
EXISTING CONDITIONS B	5
DEMO A	6
DEMO B	7
SITE PLAN A	8
SITE PLAN B	9
GRADING PLAN A	10
GRADING PLAN B	11
MISC DETAILS	12

PLANS PREPARED FOR:
MIKE LEE
(386) 965-0590

REVISED BID SET 12/23
NOT FOR CONSTRUCTION

ENGINEER OF RECORD:
BRIAN JAMES PITMAN, P.E.
PE LICENSE NUMBER: 87495
BPITMAN@PITMANENGINEERING.COM
(386) 965-5919

FIRM NAME AND CONTACT INFORMATION:
PITMAN ENGINEERING
465 E DUVAL ST
LAKE CITY, FL 32955
(386) 965-5919
PITMANENGINEERING.COM
DBPR REGISTRY #: 3013

PROJECT NAME AND SITE ADDRESS:
FGC DRAINAGE IMPROVEMENTS
132 SE FOUNDATION PLACE
COLUMBIA COUNTY, FLORIDA

SHEET NAME:
KEY SHEET
DATE:
12/23
PROJECT NUMBER:
23-16FGC
SHEET #:
1

GENERAL

1. THIS PROJECT IS TO BE CONSTRUCTED IN ACCORDANCE WITH THE F.D.O.T. STANDARD SPECIFICATIONS FOR ROAD AND BRIDGE CONSTRUCTION (CURRENT EDITION) AND THE F.D.O.T. STANDARD PLANS FOR ROAD AND BRIDGE CONSTRUCTION (CURRENT EDITION), AND COLUMBIA COUNTY LAND DEVELOPMENT STANDARDS/CODES UNLESS OTHERWISE NOTED.
2. CONTRACTOR MUST GET PRIOR APPROVAL, FROM ENGINEER AND/OR OWNER, BEFORE STARTING WORK THAT WILL BE PAID FOR VIA CHANGE ORDER OR PRIOR TO USE OF ALTERNATIVE MATERIALS.
3. THE CONTRACTOR SHALL MAINTAIN THE CONSTRUCTION SITE IN A SECURE MANNER. ALL OPEN TRENCHES AND EXCAVATED AREAS SHALL BE PROTECTED FROM ACCESS BY THE GENERAL PUBLIC.
4. CONTRACTOR SHALL COORDINATE ALL WORK WITH OTHER CONTRACTORS WITHIN PROJECT AREA.

PRIOR TO START OF CONSTRUCTION

1. THE CONTRACTOR SHALL SUBMIT A NATIONAL POLLUTANT DISCHARGE ELIMINATION SYSTEM NOTICE OF INTENT ALONG WITH SUPPORTING DOCUMENTATION TO THE FLORIDA DEPARTMENT OF ENVIRONMENTAL PROTECTION AT LEAST 48 HOURS PRIOR TO BEGINNING OF CONSTRUCTION. THE CONTRACTOR SHALL BE RESPONSIBLE FOR ALL PERMIT FEES.
2. THE CONTRACTOR SHALL NOTIFY THE COUNTY AT LEAST 48 HOURS PRIOR TO BEGINNING OF CONSTRUCTION.
3. THE CONTRACTOR SHALL SUBMIT A NOTICE OF CONSTRUCTION COMMENCEMENT TO THE WATER MANAGEMENT DISTRICT AT LEAST 48 HOURS PRIOR TO THE BEGINNING OF CONSTRUCTION.
4. THE CONTRACTOR SHALL VERIFY ALL EXISTING CONDITIONS ON THE PROJECT SITE TO ENSURE THAT ALL PROPOSED WORK WILL FIT AS PLANS INTENT. IF DISCREPANCIES ARE FOUND, THE CONTRACTOR SHALL STOP WORK AND NOTIFY THE ENGINEER OF SUCH DIFFERENCES IMMEDIATELY. THE CONTRACTOR, ENGINEER, AND OWNER SHALL WORK TO RESOLVE THE ISSUE AS QUICKLY AND ECONOMICALLY AS POSSIBLE.
5. THE LOCATION OF THE UTILITIES SHOWN IN THE PLANS ARE APPROXIMATE ONLY. THE EXACT LOCATION SHALL BE DETERMINED BY THE CONTRACTOR DURING CONSTRUCTION. CONTRACTOR SHALL PROTECT ALL UTILITIES WITHIN THE PROJECT AREAS.
6. THE CONTRACTOR SHALL IMPLEMENT ALL COMPONENTS OF THE EROSION AND SEDIMENTATION CONTROL PLAN PRIOR TO ANY EARTH DISTURBING ACTIVITIES. ALL COMPONENTS SHALL BE MAINTAINED BY THE CONTRACTOR UNTIL ALL VEGETATION IS ESTABLISHED, THE ENTIRE PROJECT AREA IS STABILIZED AND THE OWNER HAS ACCEPTED OPERATION AND MAINTENANCE.

SURVEY/EXISTING CONDITIONS NOTES

1. TOPOGRAPHIC INFORMATION SHOWN WAS OBTAINED FROM A TOPOGRAPHIC SURVEY PREPARED BY PITMAN ENGINEERING.
2. ANY PUBLIC LAND CORNER WITHIN THE LIMITS OF CONSTRUCTION SHALL BE PROTECTED. IF A CORNER MONUMENT IS IN DANGER OF BEING DESTROYED AND HAS NOT BEEN PROPERLY REFERENCED, THE CONTRACTOR SHOULD NOTIFY THE ENGINEER.
3. THE SITE IS LOCATED IN SECTION 01, TOWNSHIP 4 SOUTH, RANGE 17 EAST, COLUMBIA COUNTY, FLORIDA.

DURING CONSTRUCTION

1. ALL DISTURBED AREAS NOT SODDED SHALL BE SEEDED WITH A MIXTURE OF LONG-TERM VEGETATION AND QUICK GROWING SHORT-TERM VEGETATION FOR THE FOLLOWING CONDITIONS. FOR THE MONTHS FROM SEPTEMBER THROUGH MARCH, THE MIX SHALL CONSIST OF 70 POUNDS PER ACRE OF LONG-TERM SEED AND 20 POUNDS PER ACRE OF WINTER RYE. FOR THE MONTHS OF APRIL THROUGH AUGUST, THE MIX SHALL CONSIST OF 70 POUNDS PER ACRE OF LONG-TERM SEED AND 20 POUNDS PER ACRE OF MILLET.
2. IF UNSUITABLE MATERIAL IS ENCOUNTERED DURING GRADING, CONTRACTOR SHALL REMOVE UNSUITABLE MATERIAL TO A DEPTH OF 24" BELOW FINISHED GRADE WITHIN THE CONSTRUCTION LIMITS.
3. THE CONTRACTOR SHALL WASTE ALL EXCESS EARTH ON SITE AS DIRECTED BY THE OWNER. ENGINEER SHALL APPROVE WASTE LOCATION TO ENSURE LOCATION DOES NOT CHANGE OR IMPEDE STORMWATER CONVEYANCE AS INTENDED BY THE GRADING PLAN.

EROSION CONTROL PLAN & NOTES

1. THIS EROSION AND SEDIMENTATION CONTROL PLAN COMPLIES WITH THE REQUIREMENTS OF THE "FLORIDA DEVELOPMENT MANUAL" AND THE "FLORIDA EROSION AND SEDIMENT CONTROL INSPECTOR'S MANUAL".
2. THE CONTRACTOR SHALL ADHERE TO COLUMBIA COUNTY, SRWMD, AND OTHER GOVERNING AUTHORITIES FOR EROSION AND SEDIMENT CONTROL REGULATIONS. IF THE CONTRACTOR NEEDS TO CHANGE THIS PLAN TO MORE EFFECTIVELY CONTROL EROSION AND SEDIMENTATION, THE CONTRACTOR SHALL USE BMP'S FROM THE "FLORIDA EROSION AND SEDIMENT CONTROL INSPECTOR'S MANUAL".
3. THE CONTRACTOR SHALL ADJUST AND REVISE THIS PLAN TO MEET ACTUAL FIELD CONDITIONS. ANY REVISIONS SHALL BE APPROVED BY THE REVIEWING AGENCIES.
4. SEDIMENT AND EROSION CONTROL FACILITIES, STORM DRAINAGE FACILITIES AND DETENTION BASINS SHALL BE INSTALLED PRIOR TO ANY OTHER CONSTRUCTION.
5. EROSION CONTROL MEASURES SHALL BE INSPECTED WEEKLY AND AFTER EACH RAINFALL OF 0.5 INCHES OR GREATER, AND REPAIRED OR REPLACED AS NECESSARY.
6. SEDIMENT AND EROSION CONTROL MEASURES SHALL NOT BE REMOVED UNTIL ALL CONSTRUCTION IS COMPLETE AND UNTIL A PERMANENT GROUND COVER HAS BEEN ESTABLISHED.
7. ALL OPEN DRAINAGE SWALES SHALL BE GRASSED AND RIPRAP SHALL BE PLACED AS REQUIRED TO CONTROL EROSION.
8. SILT FENCES SHALL BE LOCATED ON SITE TO PREVENT SEDIMENT AND EROSION FROM LEAVING PROJECT LIMITS.
9. CONTRACTOR SHALL PLACE A DOUBLE ROW OF SILT FENCE IN AREAS WHERE RUNOFF FROM DISTURBED AREAS MAY ENTER WETLANDS.
10. DURING CONSTRUCTION AND AFTER CONSTRUCTION IS COMPLETE, ALL STRUCTURES SHALL BE CLEANED OF ALL DEBRIS AND EXCESS SEDIMENT.
11. ALL GRADED AREAS SHALL BE STABILIZED IMMEDIATELY WITH A TEMPORARY FAST-GROWING COVER AND/OR MULCH.
12. A PAD OF RUBBLE RIP RAP SHALL BE PLACED AT THE BOTTOM OF ALL COLLECTION FLUMES AND COLLECTION PIPE OUTLETS. GRANITE OR LIMESTONE RIPRAP IS REQUIRED, NO BROKEN CONCRETE WILL BE ACCEPTED.
13. ALL SIDE SLOPES STEEPER THAN 3:1 SHALL BE ADEQUATELY PROTECTED FROM EROSION THROUGH THE USE OF SYNTHETIC BALES OR SODDING.
14. ALL STABILIZATION PRACTICES SHALL BE INITIATED AS SOON AS PRACTICABLE IN AREAS OF THE JOB WHERE CONSTRUCTION ACTIVITIES HAVE TEMPORARILY OR PERMANENTLY STOPPED, BUT IN NO CASE SHALL THE DISTURBED AREA BE LEFT UNPROTECTED FOR MORE THAN SEVEN DAYS.
15. ALL WASTE GENERATED ON THE PROJECT SHALL BE DISPOSED OF BY THE CONTRACTOR IN AREAS PROVIDED BY CONTRACTOR.
16. LOADED HAUL TRUCKS SHALL BE COVERED WITH TARP.
17. EXCESS DIRT SHALL BE REMOVED DAILY.
18. THIS PROJECT SHALL COMPLY WITH ALL WATER QUALITY STANDARDS. PERMIT REQUIRED FROM SRWMD HAS BEEN OBTAINED.
19. QUALIFIED PERSONNEL SHALL INSPECT THE AREA USED FOR STORAGE OF STOCKPILES, THE SILT FENCE AND STRAW BALES, THE LOCATION WHERE VEHICLES ENTER OR EXIT THE SITE, AND THE DISTURBED AREAS THAT HAVE NOT BEEN FINALLY STABILIZED, AT LEAST ONCE EVERY SEVEN CALENDAR DAYS AND WITHIN 24 HOURS OF THE END OF A STORM OF 0.5 INCHES OR GREATER.
20. SITES THAT HAVE BEEN FINALLY STABILIZED WITH SOD OR GRASSING SHALL BE INSPECTED AT LEAST ONCE EVERY WEEK.

POST-CONSTRUCTION

1. CONTRACTOR SHALL PROVIDE AN AS-BUILT SURVEY MEETING THE REQUIREMENTS OF CHAPTER 61G17 F.A.C. FOR THE STORMWATER MANAGEMENT SYSTEMS. INCLUDE HORIZONTAL AND VERTICAL DIMENSIONAL DATA SO THAT IMPROVEMENTS ARE LOCATED AND DELINEATED RELATIVE TO THE BOUNDARY. PROVIDE SUFFICIENT DETAILED DATA TO DETERMINE WHETHER THE IMPROVEMENTS WERE CONSTRUCTED IN ACCORDANCE WITH THE PLANS. A COPY OF THE AS-BUILT SURVEY (IN PAPER AND DIGITAL AUTOCAD FORMAT) MUST BE SUBMITTED TO THE CITY OF LAKE CITY, FLORIDA (DEPARTMENT OF GROWTH MANAGEMENT) AND THE ENGINEER.

ENGINEER OF RECORD:
BRIAN JAMES PITMAN, P.E.
 PE LICENSE NUMBER: 87495
 BPITMAN@PITMANENGINEERING.COM
 (386) 965-5919

FIRM NAME AND CONTACT INFORMATION:
PITMAN ENGINEERING
 468 E DUVAL ST
 LAKE CITY, FL 32055
 (386) 965-5919
 BPITMAN@PITMANENGINEERING.COM
 DPR REGISTRY #: 3013

PROJECT NAME AND SITE ADDRESS:
FGC DRAINAGE IMPROVEMENTS
 132 SE FOUNDATION PLACE
 COLUMBIA COUNTY, FLORIDA

SHEET NAME:
NOTES
 DATE:
 12/23
 PROJECT NUMBER:
 23-16FGC

SHEET #
2

THE OFFICIAL RECORD OF THIS SHEET IS THE ELECTRONIC FILE DIGITALLY SIGNED AND SEALED UNDER RULE 61G15-23.004, F.A.C.

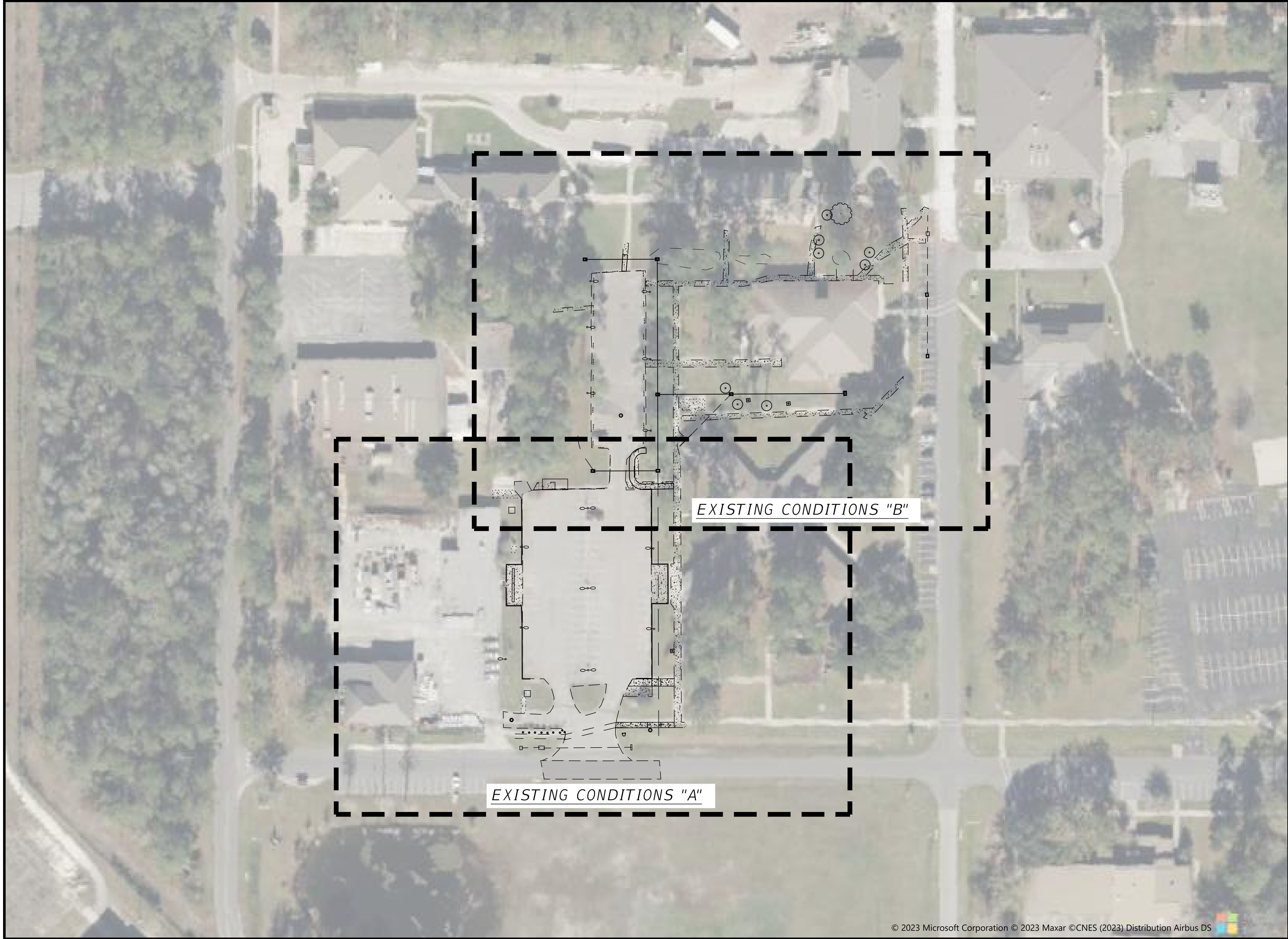

EXISTING CONDITIONS "A"

EXISTING CONDITIONS "B"

SHEET NAME
OVERALL SITE PLAN
 DATE
 12/23
 PROJECT NUMBER
 23-16FGC

SHEET #
3

PROJECT NAME AND SITE ADDRESS

FGC DRAINAGE IMPROVEMENTS
 132 SE FOUNDATION PLACE
 COLUMBIA COUNTY, FLORIDA

FIRM NAME AND CONTACT INFORMATION:

PE
PITMAN ENGINEERING
 465 E DUVAL ST
 LAKE CITY, FL 32055
 (386) 965-5919
 PITMANENGINEERING.COM
 DPRR REGISTRY #: 3013

ENGINEER OF RECORD:

BRIAN JAMES PITMAN, P.E.
 PE LICENSE NUMBER: 87495
 BPITMAN@PITMANENGINEERING.COM
 (386) 965-5919



ENGINEER OF RECORD:
BRIAN JAMES PITMAN, P.E.
 PE LICENSE NUMBER: 87495
 BPITMAN@PITMANENGINEERING.COM
 (386) 965-5919

FIRM NAME AND CONTACT INFORMATION:
PITMAN ENGINEERING
 405 E DUVAL ST
 LAKE CITY, FL 32055
 (386) 965-5919
 BPITMAN@PITMANENGINEERING.COM
 DPRR REGISTRY #: 3013

PROJECT NAME AND SITE ADDRESS
FGC DRAINAGE IMPROVEMENTS
 132 SE FOUNDATION PLACE
 COLUMBIA COUNTY, FLORIDA

SHEET NAME:
EXISTING CONDITIONS A
 DATE: 12/23
 PROJECT NUMBER: 23-16FGC
 SHEET: 4

THE OFFICIAL RECORD OF THIS SHEET IS THE ELECTRONIC FILE DIGITALLY SIGNED AND SEALED UNDER RULE 61G15-23.004, F.A.C.



ENGINEER OF RECORD:
BRIAN JAMES PITMAN, P.E.
 PE LICENSE NUMBER: 87495
 BPITMAN@PITMANENGINEERING.COM
 (386) 965-5919

FIRM NAME AND CONTACT INFORMATION:
PITMAN ENGINEERING
 465 E DUVAL ST
 LAKE CITY, FL 32055
 (386) 965-5919
 BPITMAN@PITMANENGINEERING.COM
 DPRR REGISTRY #: 3013

PROJECT NAME AND SITE ADDRESS
FGC DRAINAGE IMPROVEMENTS
 132 SE FOUNDATION PLACE
 COLUMBIA COUNTY, FLORIDA

SHEET NAME
EXISTING CONDITIONS B
 DATE: 12/23
 PROJECT NUMBER: 23-16FGC
 SHEET # **5**

THE OFFICIAL RECORD OF THIS SHEET IS THE ELECTRONIC FILE DIGITALLY SIGNED AND SEALED UNDER RULE 61G15-23.004, F.A.C.



ENGINEER OF RECORD:
BRIAN JAMES PITMAN, P.E.
 PE LICENSE NUMBER: 87495
 BPITMAN@PITMANENGINEERING.COM
 (386) 965-5919

FIRM NAME AND CONTACT INFORMATION:
PITMAN ENGINEERING
 465 E DUVAL ST
 LAKE CITY, FL 32055
 (386) 965-5919
 BPITMAN@PITMANENGINEERING.COM
 DPRR REGISTRY #: 3013

PROJECT NAME AND SITE ADDRESS
FGC DRAINAGE IMPROVEMENTS
 132 SE FOUNDATION PLACE
 COLUMBIA COUNTY, FLORIDA

SHEET NAME
DEMO A

DATE
 12/23

PROJECT NUMBER
 23-16FGC

SHEET #
6

THE OFFICIAL RECORD OF THIS SHEET IS THE ELECTRONIC FILE DIGITALLY SIGNED AND SEALED UNDER RULE 61G15-23.004, F.A.C.



ENGINEER OF RECORD:
BRIAN JAMES PITMAN, P.E.
 PE LICENSE NUMBER: 87495
 BPITMAN@PITMANENGINEERING.COM
 (386) 965-5919

FIRM NAME AND CONTACT INFORMATION:
PITMAN ENGINEERING
 465 E DUVAL ST
 LAKE CITY, FL 32055
 (386) 965-5919
 BPITMAN@PITMANENGINEERING.COM
 DPRR REGISTRY #: 3013

PROJECT NAME AND SITE ADDRESS
FGC DRAINAGE IMPROVEMENTS
 132 SE FOUNDATION PLACE
 COLUMBIA COUNTY, FLORIDA

SHEET NAME
DEMO B

DATE
 12/23

PROJECT NUMBER
 23-16FGC

SHEET #
7

THE OFFICIAL RECORD OF THIS SHEET IS THE ELECTRONIC FILE DIGITALLY SIGNED AND SEALED UNDER RULE 61G15-23.004, F.A.C.

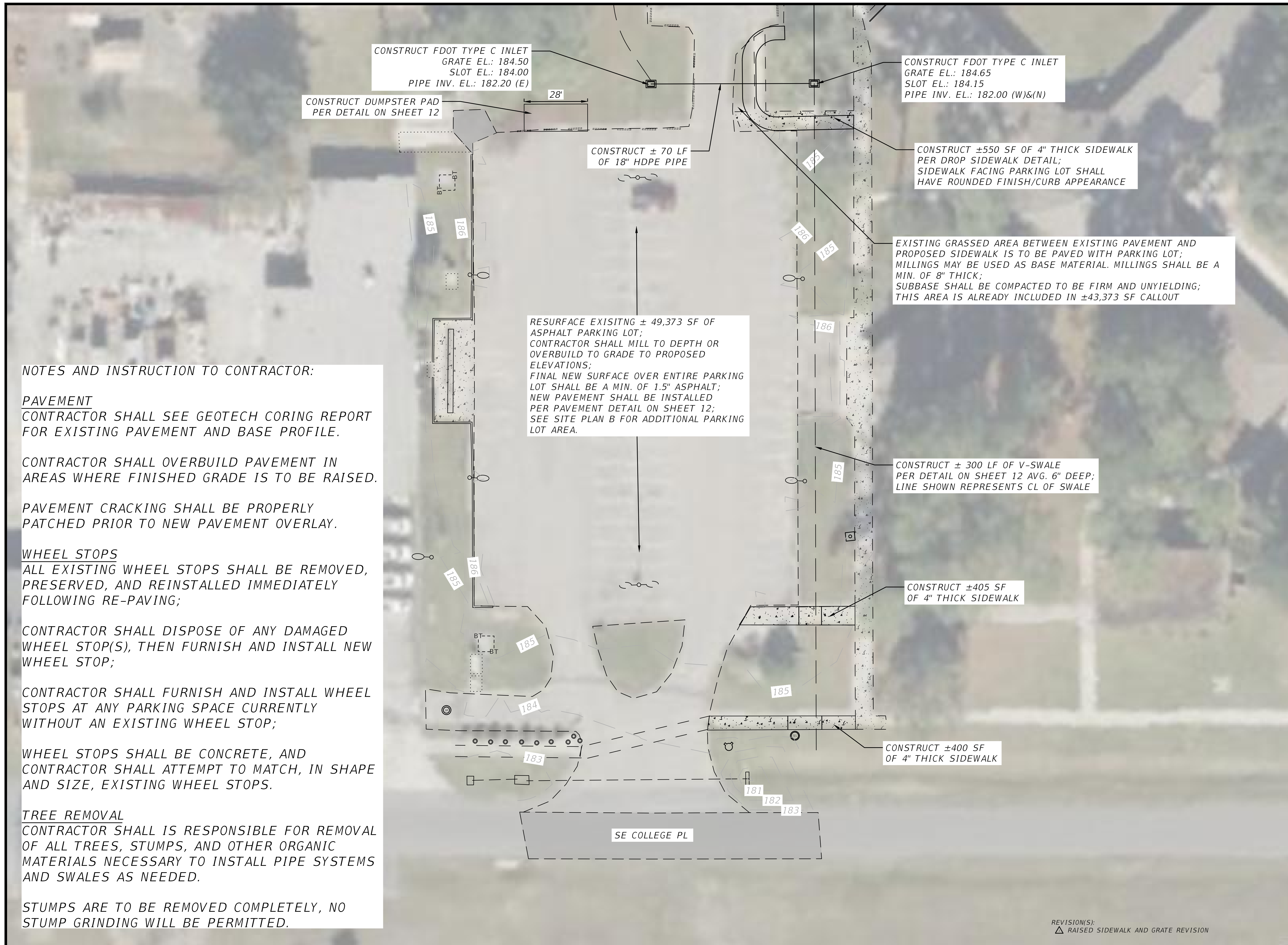

NOTES AND INSTRUCTION TO CONTRACTOR:

PAVEMENT

CONTRACTOR SHALL SEE GEOTECH CORING REPORT FOR EXISTING PAVEMENT AND BASE PROFILE.

CONTRACTOR SHALL OVERBUILD PAVEMENT IN AREAS WHERE FINISHED GRADE IS TO BE RAISED.

PAVEMENT CRACKING SHALL BE PROPERLY PATCHED PRIOR TO NEW PAVEMENT OVERLAY.

WHEEL STOPS

ALL EXISTING WHEEL STOPS SHALL BE REMOVED, PRESERVED, AND REINSTALLED IMMEDIATELY FOLLOWING RE-PAVING;

CONTRACTOR SHALL DISPOSE OF ANY DAMAGED WHEEL STOP(S), THEN FURNISH AND INSTALL NEW WHEEL STOP;

CONTRACTOR SHALL FURNISH AND INSTALL WHEEL STOPS AT ANY PARKING SPACE CURRENTLY WITHOUT AN EXISTING WHEEL STOP;

WHEEL STOPS SHALL BE CONCRETE, AND CONTRACTOR SHALL ATTEMPT TO MATCH, IN SHAPE AND SIZE, EXISTING WHEEL STOPS.

TREE REMOVAL

CONTRACTOR SHALL IS RESPONSIBLE FOR REMOVAL OF ALL TREES, STUMPS, AND OTHER ORGANIC MATERIALS NECESSARY TO INSTALL PIPE SYSTEMS AND SWALES AS NEEDED.

STUMPS ARE TO BE REMOVED COMPLETELY, NO STUMP GRINDING WILL BE PERMITTED.

ENGINEER OF RECORD:
BRIAN JAMES PITMAN, P.E.
PE LICENSE NUMBER: 87495
BPITMAN@PITMANENGINEERING.COM
(386) 965-5919

FIRM NAME AND CONTACT INFORMATION:
PITMAN ENGINEERING
468 E DUVAL ST
LAKE CITY, FL 32055
(386) 965-5919
PITMANENGINEERING.COM
DPR REGISTRY #: 3013

PROJECT NAME AND SITE ADDRESS
FGC DRAINAGE IMPROVEMENTS
132 SE FOUNDATION PLACE
COLUMBIA COUNTY, FLORIDA

SHEET NAME
SITE PLAN A

DATE
12/23

PROJECT NUMBER
23-16FGC

SHEET #
8

REVISION(S):
△ RAISED SIDEWALK AND GRATE REVISION

NOTE:
CONTRACTOR SHALL SEE NOTES ON PREVIOUS SHEET



ENGINEER OF RECORD:
BRIAN JAMES PITMAN, P.E.
PE LICENSE NUMBER: 87495
BPITMAN@PITMANENGINEERING.COM
(386) 965-5919

FIRM NAME AND CONTACT INFORMATION:
PITMAN ENGINEERING
465 E DUVAL ST
LAKE CITY, FL 32055
(386) 965-5919
PITMANENGINEERING.COM
DPR REGISTRY #: 3013

PROJECT NAME AND SITE ADDRESS
FGC DRAINAGE IMPROVEMENTS
132 SE FOUNDATION PLACE
COLUMBIA COUNTY, FLORIDA

SHEET NAME
SITE PLAN B

DATE
12/23

PROJECT NUMBER
23-16FGC

SHEET #
9

REVISION(S):
△ RAISED SIDEWALK AND GRATE REVISION

THE OFFICIAL RECORD OF THIS SHEET IS THE ELECTRONIC FILE DIGITALLY SIGNED AND SEALED UNDER RULE 61G15-23.004, F.A.C.

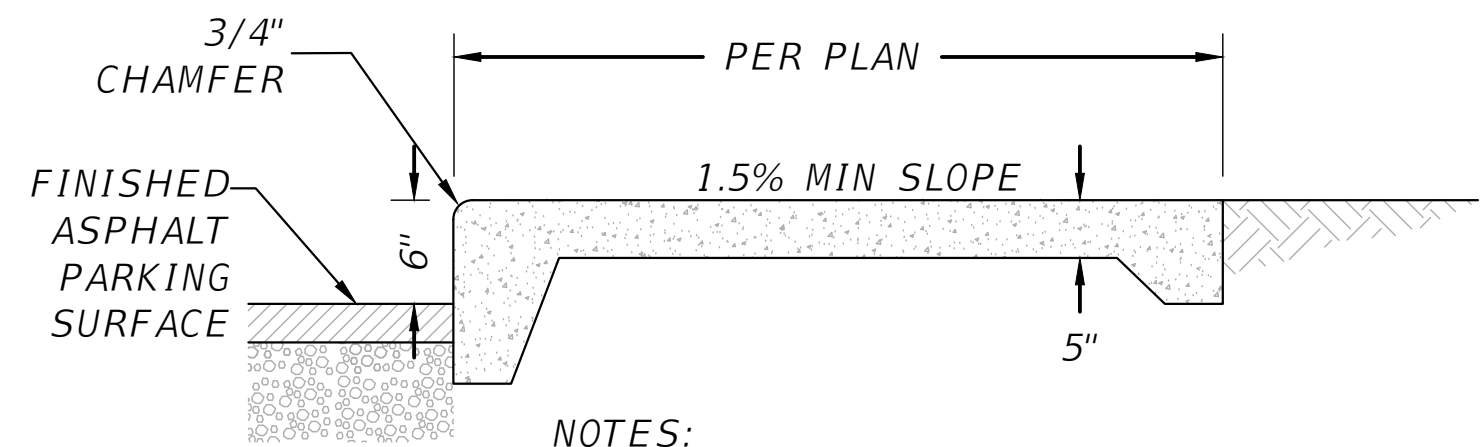

- NOTES:
 1) 6' CONTROL JOINT
 2) 18' EXPANSION JOINT
 3) BROOM FINISH

CONCRETE DROP SIDEWALK DETAIL

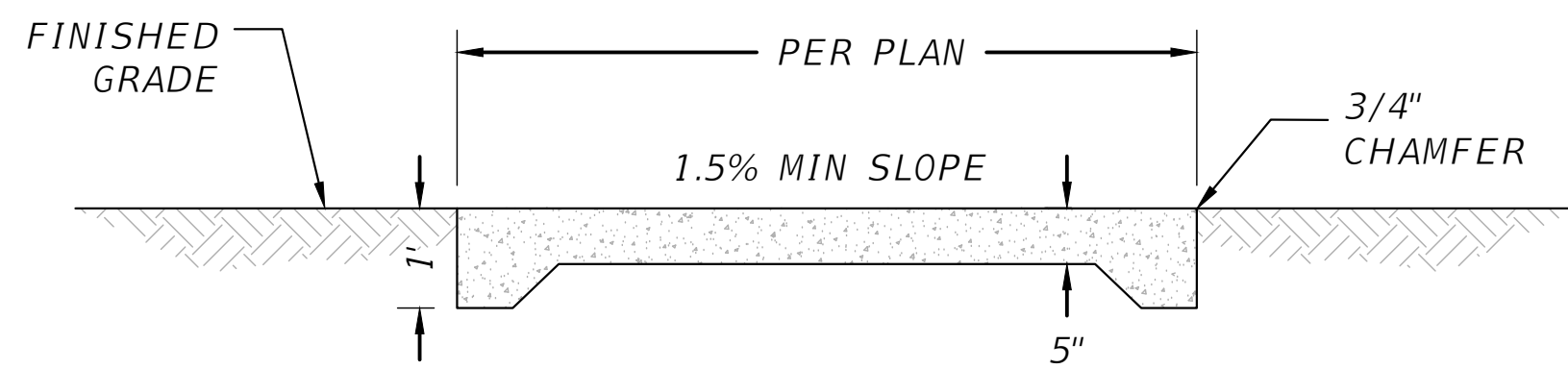

- NOTES:
 1) 6' CONTROL JOINT
 2) 18' EXPANSION JOINT
 3) BROOM FINISH

CONCRETE SIDEWALK DETAIL

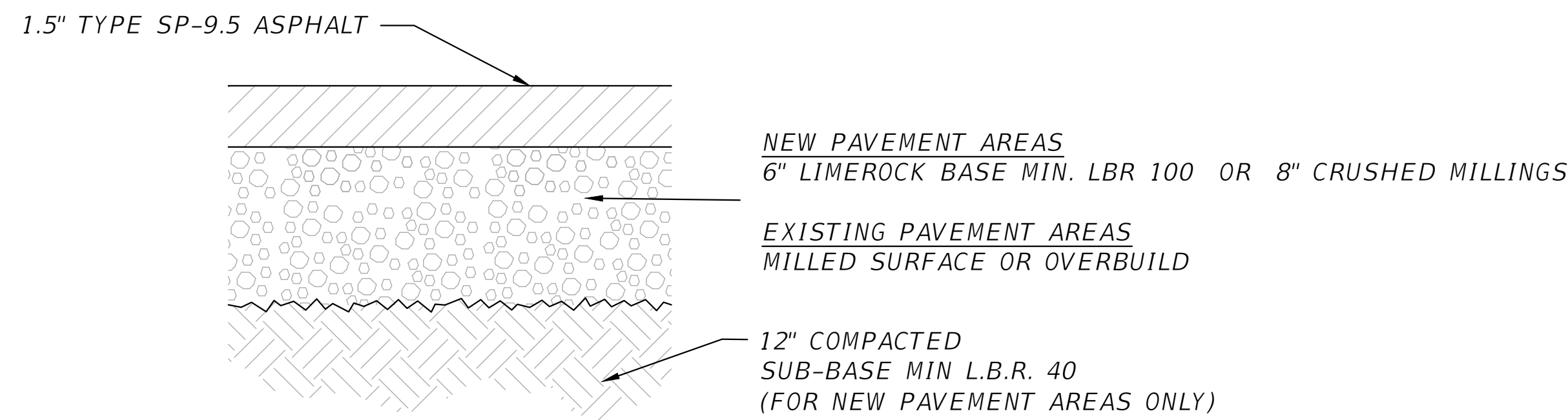

- NOTES:
 1. IF EXISTING SOIL UNABLE TO BE COMPACTED TO L.B.R. 40 FOR SUBBASE, CONTRACTOR SHALL OVEREXCAVATE AND BACKFILL WITH TYPE B STABILIZATION PER FDOT ROADWAY DESIGN MANUAL.

NEW PAVEMENT PROFILE TYPICAL SECTION

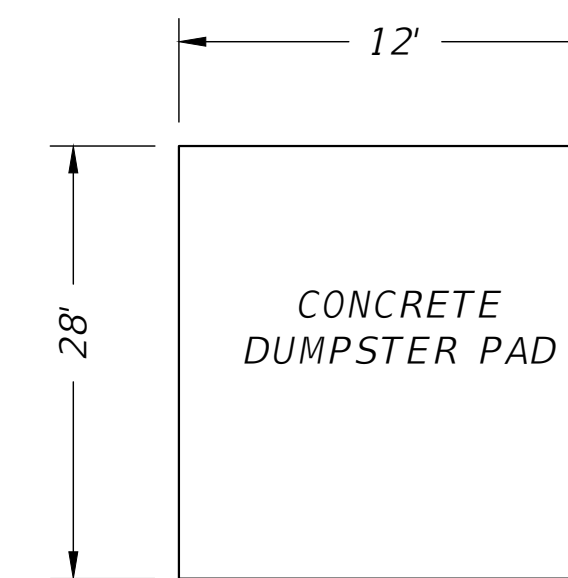

PLAN VIEW

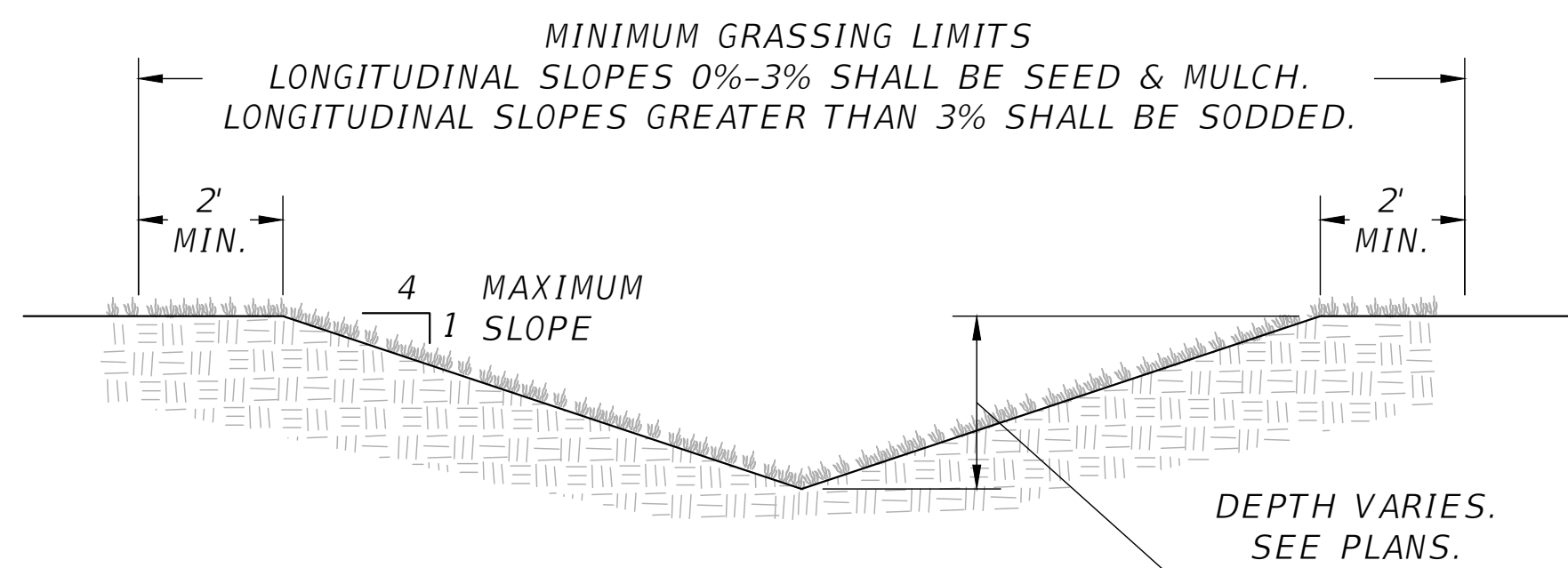

GRASSED V SWALE

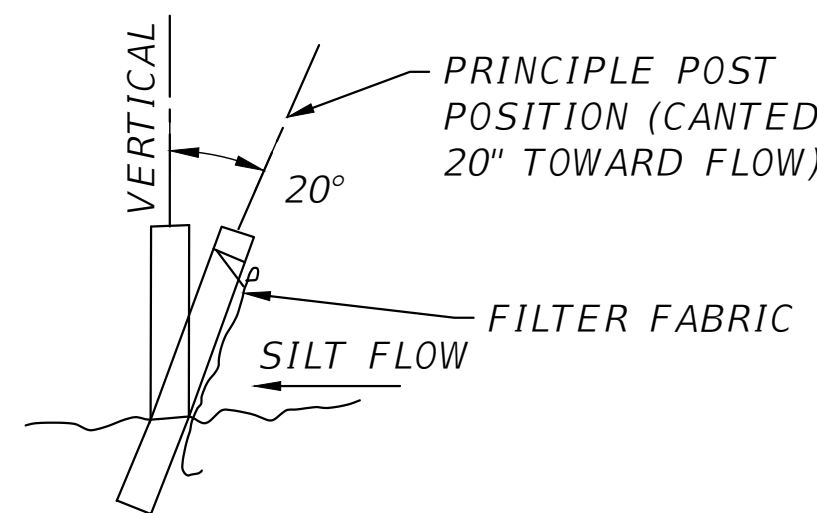

SECTION

- POST OPTIONS:
 SOFTWOOD 4" MIN. DIA.
 SOFTWOOD 4" x 4"
 HARDWOOD 3" DIA.
 STEEL 1.33 LBS/FT. MIN.

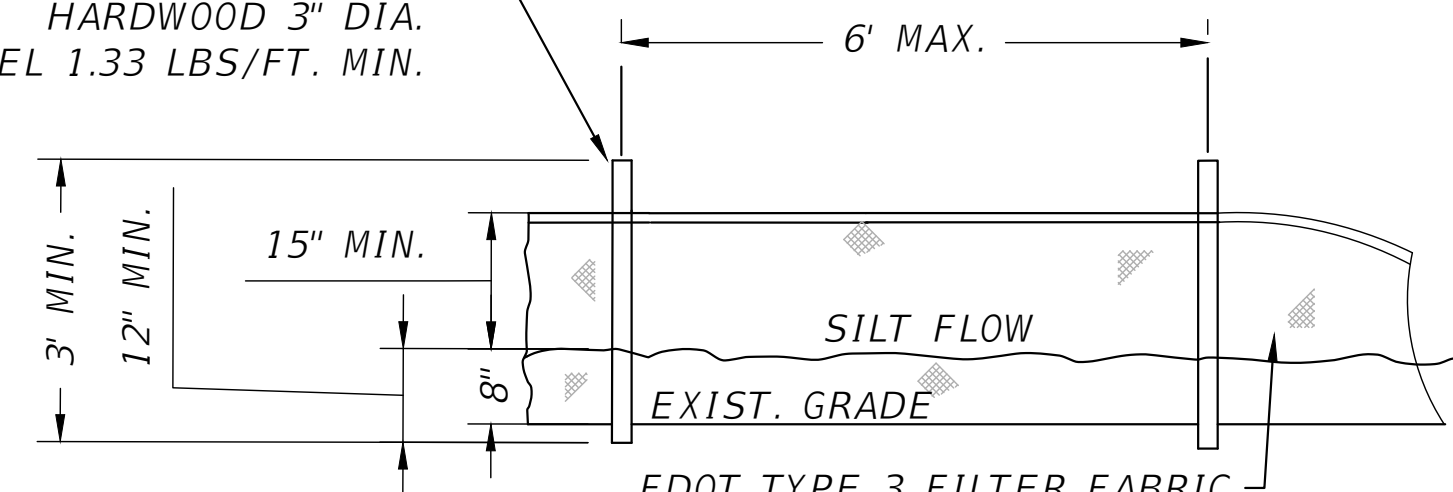

ELEVATION

SILT FENCE DETAIL

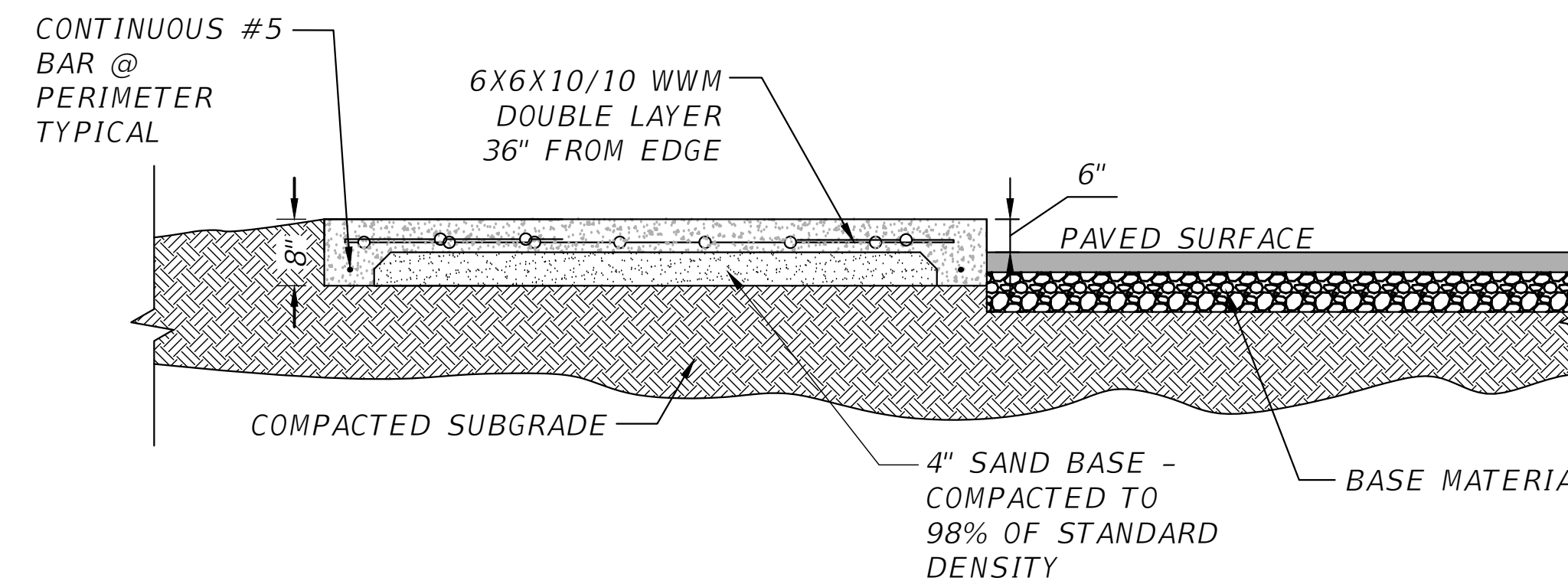

SECTION VIEW

CONCRETE NOTES:

- 1) THE DESIGN OF FOUNDATIONS AND SLAB-ON-GRADE IS BASED ON AN ASSUMED MINIMUM BEARING CAPACITY OF 2,000 PSF.
- 2) THE AREA UNDER FOOTINGS, FOUNDATIONS, AND CONCRETE SLABS-ON-GRADE SHALL HAVE ALL VEGETATION, STUMPS, ROOTS, AND FOREIGN MATERIALS REMOVED PRIOR TO THEIR CONSTRUCTION. FILL MATERIAL AND BACKFILL MATERIAL SHALL BE FREE OF ORGANIC MATERIAL, CONSTRUCTION DEBRIS, LARGE ROCKS, AND ANY OTHER FOREIGN MATERIAL.
- 3) THE CONTRACTOR SHALL INVESTIGATE ACTUAL LOCATIONS OF UNDERGROUND LINES AND UTILITIES BEFORE EXCAVATING. ALL EXCAVATIONS NEAR THESE LINES SHALL BE CARRIED OUT WITH EXTREME CAUTION.
- 4) A MINIMUM CONCRETE COVER OF 3" SHALL BE PROVIDED FOR ALL REINFORCING STEEL.
- 5) REINFORCING STEEL:
 REINFORCING STEEL BARS.....ASTM A-615 GRADE 40
 WELDED WIRE FABRIC.....ASTM A-185

DUMPSTER PAD DETAIL

ENGINEER OF RECORD:
BRIAN JAMES PITMAN, P.E.
 PE LICENSE NUMBER: 87495
 BPITMAN@PITMANENGINEERING.COM
 (386) 965-5919

FIRM NAME AND CONTACT INFORMATION:
PITMAN ENGINEERING
 465 E DUVAL ST.
 LAKE CITY, FL 32955
 (386) 965-5919
 BPITMAN@PITMANENGINEERING.COM
 DPR REGISTRY #: 3013

PROJECT NAME AND SITE ADDRESS:
FGC DRAINAGE IMPROVEMENTS
 132 SE FOUNDATION PLACE
 COLUMBIA COUNTY, FLORIDA

SHEET NAME:
MISC DETAILS
 DATE:
 12/23
 PROJECT NUMBER:
 23-16FGC
 SHEET #:
 12

ATTACHMENT NO. 14
Pavement Evaluation Report



Cal -Tech Testing, Inc.

- Engineering
- Geotechnical
- Environmental

LABORATORIES

P.O. Box 1625 • Lake City, FL 32056
Tel. (386) 755-3633 • Fax (386) 752-5456

7540 103rd Street, Suite 215, Jacksonville, FL 32210
Tel. (904) 381-8901 • Fax (904) 381-8902

November 27, 2023

Mr. Mike Lee
Florida Gateway College
149 SE College Place
Lake City, Florida 32025

**RE: Roadway Pavement Evaluation Report
Florida Gateway College-Parking Lot Driveway Pavement
Lake City, Florida
Cal-Tech Testing Inc. Project No. 23-00533-01**

Dear Mr. Mike Lee:

This report presents the results of our roadway pavement evaluation work performed throughout a Florida Gateway College parking lot driveway in Lake City, Florida.

The purposes of the evaluation were to determine the pavement materials, section, and subgrade soils.

ROADWAY PAVEMENT EVALUATION

Our roadway pavement evaluation work was performed on November 21, 2023, and consisted of cutting cores at the parking lot driveway pavement for a total of five (5) locations (C1 to C5). Our field crew recorded the core location Global Positioning System (GPS) coordinates using a hand-held GPS device. Refer to the enclosed Core Location Plan.

At completion, the core holes were cold-patched, and the specimens were delivered to our geotechnical engineering laboratory for their review by our geotechnical engineer.

PAVEMENT SECTION

The evaluated parking lot driveway pavement section consists of asphalt surface and Limerock (concrete at C2) base courses with thicknesses as indicated in the following table:

Core No.	Surface Course Thickness (in)	Base Course Thickness (in)	Core No.	Surface Course Thickness (in)	Base Course Thickness (in)
C1	6.0	13.25/Limerock	C2	5.50	5.50/Concrete
C3	7.0	13.0/Limerock	C4	4.00	13.0/Limerock
C5	3.00	9.25/Limerock	-	-	-

Photos of the asphalt core specimens are enclosed with this report.

Very dark gray to light gray SAND (A-3) was encountered underlying the pavement base course at all core locations.

LIMITATIONS

Information about the pavement section and subgrade material shown represent conditions encountered only at the core locations.

CLOSURE

It has been a pleasure working with you and we look forward to continuing our work on this project.

Sincerely,

Cal-Tech Testing, Inc.



Ivan E. Marciano, P.E.
Sr. Geotechnical Engineer

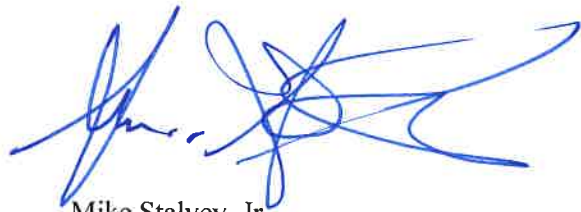

Mike Stalvey, Jr.
Vice President

Enclosures:
Core Location Plan (1 sheet)
Pavement Core Photos (1 sheet)



C1	30°10'25.72"N	82°34'10.58"W
C2	30°10'26.38"N	82°34'11.27"W
C3	30°10'27.27"N	82°34'10.23"W
C4	30°10'28.51"N	82°34'10.01"W
C5	30°10'29.46"N	82°34'10.03"W

BORING LOCATION PLAN
Florida Gateway College, Parking Lot Driveway Pavement
Lake City, Florida

CAL-TECH TESTING, INC.
P.O. BOX 1625
Lake City, Florida 32056-1625
Phone: (386) 755-3633
Fax: (386) 752-5456

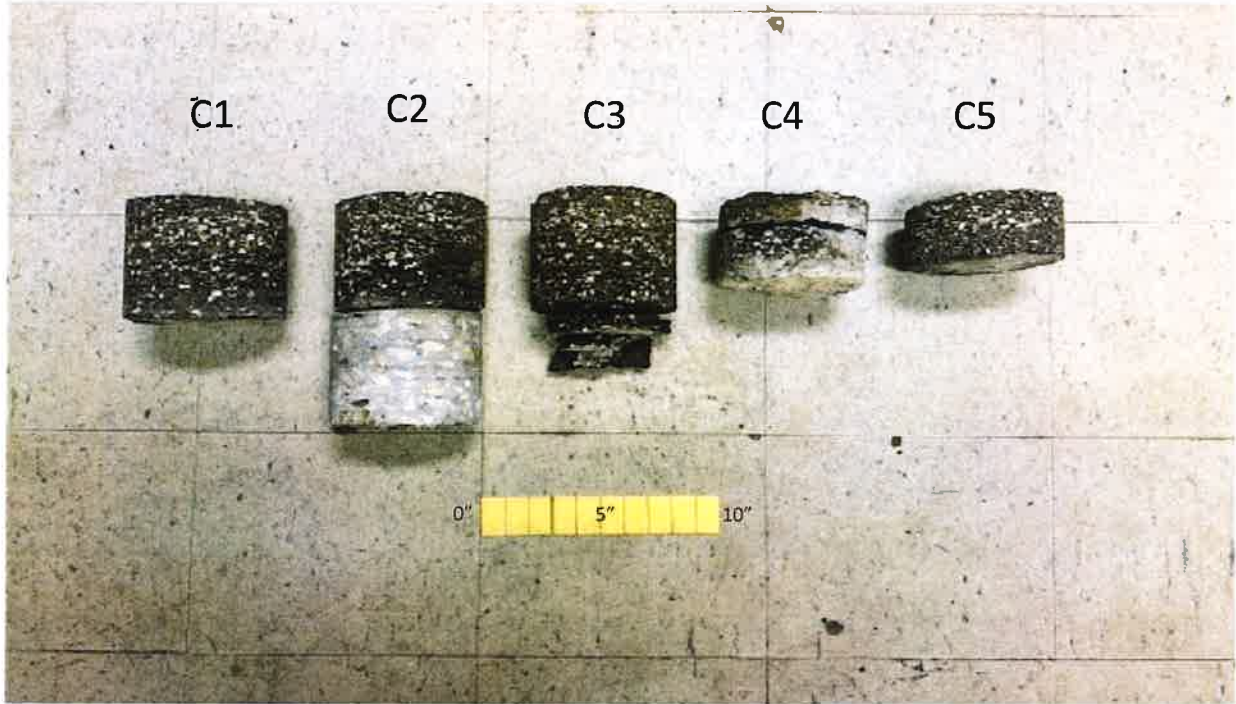

<p>CAL-TECH TESTING, INC. P.O. BOX 1625 Lake City, Florida 32056-1625 Phone: (386) 755-3633 Fax: (386) 752-5456</p>	<p>PAVEMENT CORE SPECIMEN C1-C5 Florida Gateway College-Parking Lot Driveway Pavement Lake City, Florida</p>
--	--